

MARTA LUCIANI – ARNULF HAUSLEITER (EDS.)

Recent Trends in the Study
of Late Bronze Age Ceramics
in Syro-Mesopotamia
and Neighbouring Regions

Proceedings of the International
Workshop in Berlin, 2–5 November 2006

In collaboration with
CLAUDIA BEUGER

2014



Verlag Marie Leidorf GmbH · Rahden/Westf.

X, 436 Seiten mit 130 Abbildungen, 22 Tabellen inkl. 88 Tafeln

Bibliografische Information der Deutschen Nationalbibliothek

Luciani, Marta / Hausleiter, Arnulf (Eds.):

Recent Trends in the Study of Late Bronze Age Ceramics in Syro-Mesopotamia and Neighbouring Regions ; Proceedings of the International Workshop in Berlin, 2–5 November 2006 / In collaboration with Claudia Beuger.

[Red.: Orient-Abteilung des Deutschen Archäologischen Instituts].

Rahden/Westf.: Leidorf, 2014

(Orient-Archäologie ; Bd. 32)

ISBN 978-3-89646-662-4

Die Deutsche Nationalbibliothek verzeichnet diese Publikation in der Deutschen Nationalbibliografie.
Detaillierte bibliografische Daten sind im Internet über <http://dnb.d-nb.de> abrufbar.

Gedruckt auf alterungsbeständigem Papier

Alle Rechte vorbehalten
© 2014



Verlag Marie Leidorf GmbH
Geschäftsführer: Dr. Bert Wiegel
Stellerloh 65 · D-32369 Rahden/Westf.
Tel: +49/(0)5771/95 10-74
Fax: +49/(0)5771/95 10-75
E-Mail: info@vml.de
Internet: <http://www.vml.de>

ISBN 978-3-89646-662-4
ISSN 1434-162X

Kein Teil des Buches darf in irgendeiner Form (Druck, Fotokopie, CD-ROM, DVD, BLUERAY, Internet oder einem anderen Verfahren) ohne schriftliche Genehmigung des Verlages Marie Leidorf GmbH reproduziert werden oder unter Verwendung elektronischer Systeme verarbeitet, vervielfältigt oder verbreitet werden.

Umschlagentwurf: Petra Müller, Grafikdesign, Berlin
Titelvignette: Badre–Capet (s. Fig. 12a in diesem Band)
Redaktion: Deutsches Archäologisches Institut, Orient-Abteilung, Podbielskiallee 69–71, D-14195 Berlin
[eMail: orient@dainst.de – Homepage: <http://www.dainst.org>]

Satzerstellung, Layout und Bildbearbeitung: stm|media GmbH, Köthen
Druck und Produktion: druckhaus köthen GmbH & Co. KG, Köthen

5 The Late Bronze Age Pottery of the ‘Weststadt’ of Tell Bazi (North Syria)

Adelheid Otto

The site (Fig. 1)

Tall Bazi is a Bronze Age settlement on the Mesopotamian or Jazira side of the Euphrates valley. The excavations were undertaken as part of the salvage programme in the region of the new Tishreen lake. They were conducted from 1993 to 1998 on behalf of the Damascus Branch of the Orient Department of the Deutsches Archäologisches Institut and from 1999 to 2010 on behalf of the Ludwig-Maximilians-University Munich with the financial support of the Deutsche Forschungsgemeinschaft (DFG). The project is directed by Berthold Einwag and Adelheid Otto¹.

The ancient site consists of three main parts: the most prominent is the citadel, Jebel Bazi, a 60 m high natural hill, which was heavily fortified in the late third millennium BC as a part of the fortification system of the 40 ha settlement Banat-Bazi². It continued to be used as a stronghold until the Late Bronze Age and was refortified in the Late Roman period. The summit or plateau of the citadel was occupied by a large temple in the Middle and Late Bronze Age³. In the temple were found two documents of the Mittannian kings Saushtatar and his successor Artatama concerning a place called Bašīru, which was probably the name of the site in the Late Bronze Age⁴.

The second part was the northern lower town, the *Nordstadt*, situated north of the citadel at the foot of Jebel Bazi. It has been investigated in limited soundings, which show that it was part of the lower town, occupied from at least the Middle Bronze Age to the late Late Bronze Age⁵. The ‘Nordstadt’ extended as far as the area of the modern village and was partly built over the third millennium settlement of Tall Banat⁶.

The third part is the ‘Weststadt’ (western lower town), an extension of the settlement in the Late Bronze Age. It was planned and realized as a separate city quarter and was constructed in the last

century of the existence of the city on virgin soil on a shallow river terrace. Heavily burnt debris found throughout the settlement testifies to the abrupt and violent end of the whole city.

The particular interest of the Weststadt lies in its short-term existence: there is only one level of occupation with at most two phases. Its duration can be estimated to have been less than a century. It is therefore a rare example of a settlement consisting of a considerable number of neighboring houses which were in use at precisely the same time (for the dating see below, p. 93 ff.).

The Weststadt was never settled again after the violent destruction and the Late Bronze Age remains lay immediately below the surface: in places the stone socles of the house walls were even visible on the surface. In all about 50 houses were excavated over an area of about 180 × 220 m between 1993 and 1999, when the Tishreen dam was closed and the waters of the lake began to flood the Weststadt. Since then the Weststadt has completely disappeared⁷.

¹ Our thanks are due to the Directorate General of Syrian Antiquities in Damascus, especially to Sultan Muheisen, Tammam Fakouch, Bassam Jamous and Michel Maqdissi for their generous permission and support of the excavations at Tall Bazi. I am very grateful to Michael Roaf for his critical remarks and his help with the translation. The article was finished in 2007, and only a part of the more relevant recent literature could be added before printing.

² Otto 2006b; Einwag *et al.* in prep.; for the third millennium sites Banat-village, Tall Banat and Tall Kabir see Porter 1995; Porter – McClellan 1998; Porter 2002.

³ Otto – Einwag 2007; Otto 2008a; Einwag – Otto 2012.

⁴ Sallaberger – Einwag – Otto 2006.

⁵ Einwag – Otto 2006.

⁶ For limited excavations of Late Bronze Age houses at Banat see McClellan 1991, Fig. 12. See also below.

⁷ For a detailed discussion of the Weststadt see Otto 2006a; see Einwag 2000.

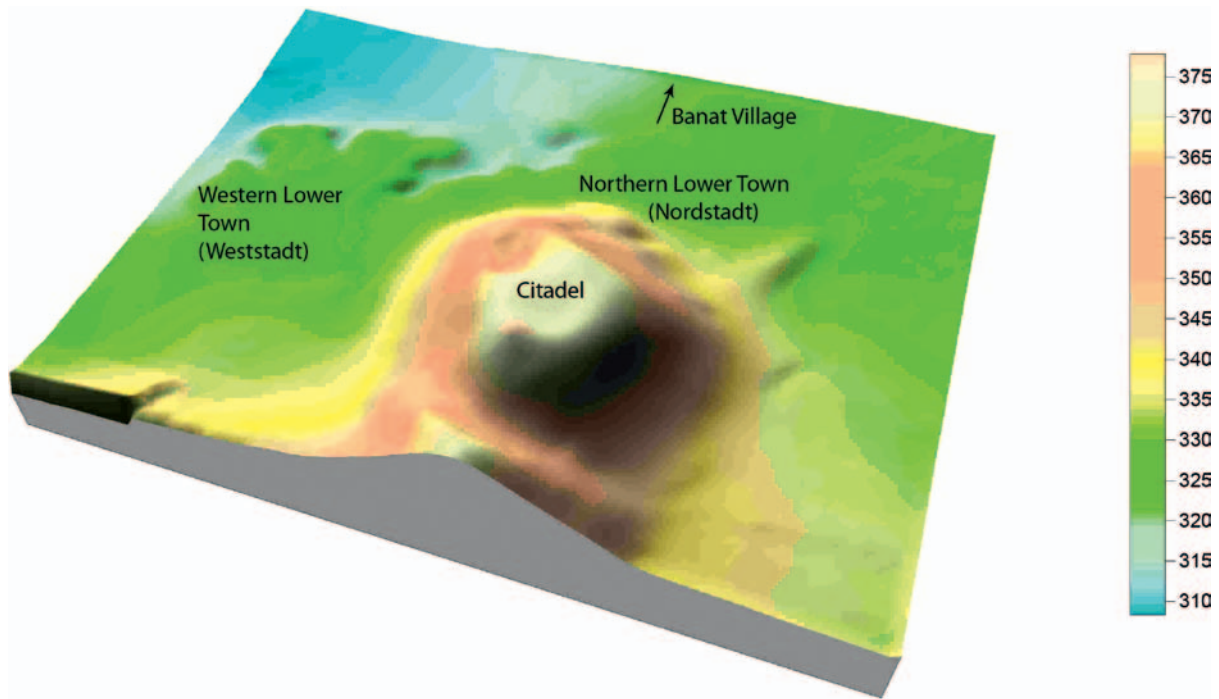

Fig. 1 The site of Tall Bazi, consisting of the Citadel, the 'Nordstadt' (continuing into Banat) and the 'Weststadt'.

الشكل ١ موقع تل بازي، ويتألف من القلعة، والمدينة الشمالية (وصولاً إلى تل البنات) و"المدينة الغربية".

The houses of the 'Weststadt' of Tall Bazi

The living quarters of the Weststadt are arranged along two main roads, one of them straight, the other curved parallel to the edge of the Euphrates terrace (Fig. 2). Both roads bordered a central open space which can probably be interpreted as a market place⁸. The layout and the regularity of the domestic quarters as well as the division of the plots show that the Weststadt was a planned settlement.

About 50 houses were excavated and the existence of 15 to 20 more can be deduced from a magnetic survey⁹. The Weststadt probably contained no more than 75 houses in total. Nearly all the houses show a highly standardised groundplan consisting of a large rectangular main room flanked on one side by a row of 3 to 6 small square rooms. A staircase near the entrance led to the roof above the main room from which the second storey above the row of small rooms was accessible: the roof could have had the same function as an internal courtyard in a house. The houses were used for social, domestic, ritual, economic, and manufacturing activities and served as well for different private, as for public purposes¹⁰.

Not only the groundplan but also the installations were highly standardized. Hearth, oven and tannur (bread oven), benches and an altar-like table in the main room belonged to every household. Uniformity and standardization are prominent characteristics of the 'Weststadt': uniform are the

form of the houses, their inventory and their use, highly standardized is the pottery.

The excavated contents and the ideal typical inventory of the 'Weststadt' houses

The Weststadt existed for only a limited time before it was completely destroyed. Some houses had been abandoned before the destruction due to various reasons (house 24, 35, 36, 37)¹¹, but the others were in use at that time and show traces of heavy burning. The violent destruction of the settlement by burning led to a well preserved archaeological inventory¹². Apparently the end came so suddenly that even valuable objects or weapons were left in the houses. There are some indications that objects were removed before the final destruction, but most probably only valuable items, not common pottery vessels of little worth¹³. This means

⁸ Otto 2006a, 266–268.

⁹ Faßbinder – Becker in Einwag – Otto 2001, 87–88, Taf. 5 d.

¹⁰ Otto 2006a, chapter 8.

¹¹ Otto 2006a, 258–60 Abb. 179.

¹² For a definition of archaeological inventory see Schiffer 1972, 156–165.

¹³ This is revealed by the inheritance documents from Emar and Munbaqa. They list wooden furniture, metal and stone objects, but not pottery. Sallaberger 1996 stresses the fact that ceramic vessels have little value in itself, but serve as package of goods.

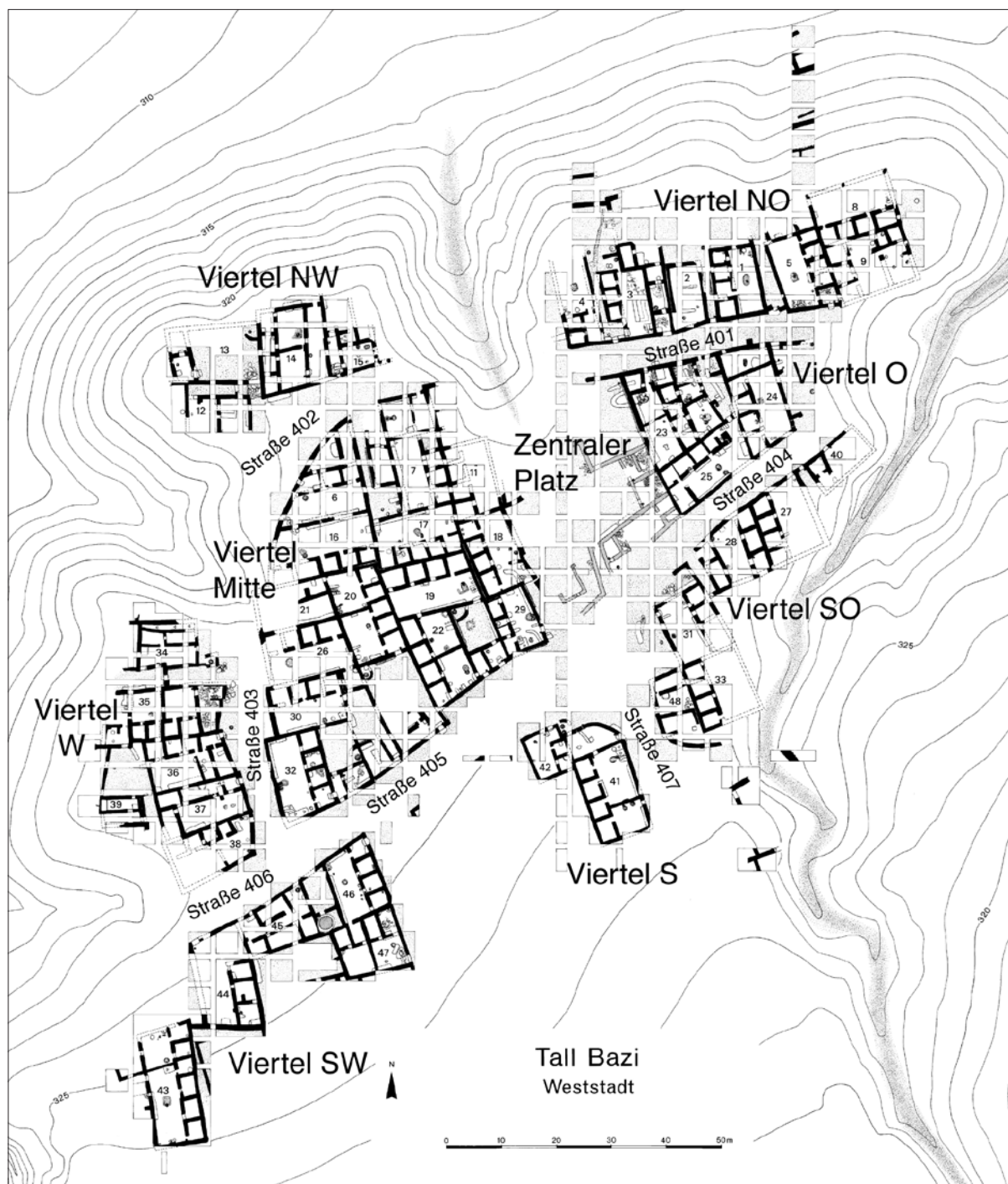

Fig. 2 The 'Weststadt of Bazi', a settlement enlargement of the Late Bronze Age.

الشكل ٢ "المدينة الغربية" في تل بزي، توسع استيطاني من عصر البرونز الحديث.

that we can consider the ceramic inventories of the houses as excavated to be nearly complete. Human actions (*e.g.* removal of objects, burning and collapse of the houses) and natural processes (erosion, decay, animal disturbances) may have led to a certain reduction of the original contents. However, the objects in the houses still furnish a rare example of a remarkably well preserved archaeological inventory¹⁴.

Several hundred pottery vessels were excavated in the 'Weststadt'¹⁵. Few of them were complete, most often the small goblets, jars or bowls, but

¹⁴ For a detailed discussion see Otto 2006a, 23–29.

¹⁵ The pottery of House 43 is discussed in Einwag – Otto 2001. For the pottery of other houses see Einwag – Otto 1999.

sometimes larger vessels which stood or lay on the floor¹⁶. The majority of the pottery was broken and considerable time and effort had to be devoted to the restoration of the vessels¹⁷. This arduous task was necessary in order to distinguish between vessels which were in use (belonging to Inventory I, see below) and intrusive residual material, e.g. sherds in the walls, in the mortar, inside the bricks, between the socle stones or between the roof beams, examples of which were found in several ‘Weststadt’ houses. According to their completeness and their location within the houses, it was then easy to distinguish between inventory consisting of pottery vessels in use which were found in the place where they were used or stored (= Inventory I), pottery vessels which were still complete but temporarily out of use¹⁸ (= Inventory II), de facto-refuse and refuse¹⁹. Here only Inventory I will be considered²⁰.

The abundance of the archaeological Inventory I made possible detailed comparative analyses of the finds and the find contexts. These enabled the recognition and definition of an ‘ideal’ house and its ‘ideal’ inventory, which are neither average nor exemplary but comprise the common characteristics of the majority of examples, similar to the concept of *idealtypus* developed by Max Weber²¹. In this way, deviations from the *idealtypus* can be easily distinguished. With respect to the pottery, foreign imports, old vessels, and exceptional vessels immediately stand out from the vessels comprising the ideal ceramic inventory.

In order to investigate the possible functional, social or other reasons for these deviations from the norm, a detailed functional analysis of every house and every room was undertaken and it was possible with the help of ethnographic analogies and taking into account of the settlement’s history and social structure (as far as it can be reconstructed with the help of cuneiform texts) to propose explanations for the anomalies.

The pottery types of the ‘Weststadt’ houses

The ceramic inventory is highly uniform and the forms are standardized. At least 20 of the 50 excavated houses contained a sufficient number of complete vessels to be sure about the general pottery types of an ideal typical inventory. 22 main vessel types were established which will be described in the following paragraphs²².

Type 1: Small goblet (Becher) (Plate 1)

Height 6–9 cm; rim diameter 4–7 cm; capacity 0.12–0.16 l.

Small vessel with a globular body, long cylindrical or curving neck, thin rim and flat, concave or convex base. 1 to 10 beakers belong to the standard ceramic inventory of a house. They were often found lying in the main room near the bench and/or near the altar. A goblet at the foot of the altar in House 26 shows that they served not only for drinking or offering wine and beer (see below chapter ‘Functional analysis’), but also for the storage of small valuable objects such as weights or beads²³.

Type 2: Small bottle with narrow neck (Enghalsiges Fläschchen) (Plate 1)

Height 8–15 cm; rim diameter 3–5 cm; capacity ca. 0.2 l.

Small vessel with globular, oval or carinated body and long, thin neck, thickened rim and round or flat base; the surface is sometimes ring-burnished and rarely painted (horizontal stripes on the shoulder)²⁴. The examples of this relatively rare type which was not found in every house, show distinct variations in form, fabric and surface treatment, which point to the local manufacture of some of them and to the import of others. Probably the bottles contained perfumed oil and were possibly called ‘satu or zadu vessels with fine oil’²⁵.

Type 3: Small ring-based pot (Topfflasche) (Plate 2)

Height 11–17.5 cm; rim diameter 7–11 cm; capacity ca. 1.4 l.

Small pot with tall, cylindrical walls, in most instances with thickened rim and ring base. The walls are quite thick in relation to the pot’s size. The lower part shows distinct variations which range from cylindrical to slightly thickened and to

¹⁶ To the latter belongs a large vat with a hole in the round bottom (Type 20), which stood upside down in room 5 of house 20-N; see Einwag – Otto 1996, Taf. 9 c.

¹⁷ It was made possible by the enormous help and meticulous work of the local specialists, especially Junis Abdallah from Banat.

¹⁸ These vessels were stored in certain rooms. Therefore, their findspots and associations cannot contribute to the interpretation of the vessels’ function.

¹⁹ For a general definition see Pfälzner 2001, 38–56; concerning the Weststadt see Otto 2006a, 26–28.

²⁰ For a definition of inventory I, II, III and refuse see Otto 2006a, 24–28.

²¹ Max Weber, *Gesammelte Aufsätze zur Wissenschaftslehre*, Tübingen 1951, 191; see Otto 2006a, 39–40.

²² Unfortunately, the absolute number of the examples can not be given here, because the analysis of the pottery for the final publication is still in progress.

²³ Otto 2006a, 97 fig. 27; Otto 2008b.

²⁴ Otto 2006a, 97 Abb. 45,1.

²⁵ Arnaud 1985–1987, 369: 86. 452: 2; Otto 2006a, 97.

globular. This is the only type of locally produced vessel that may be painted: in several instances they have painted horizontal or spiral bands. The color of the paint ranges from red to brown (Munsell: 5 YR 5/3–7.5 YR 4/2–2.5). These vessels jars were often found associated with other fine tableware or lay on or near the bench in the main room. A painted example in House 32, side room 44, was associated with a bronze filter tip from a drinking straw of the sort used when drinking beer. Form, capacity and decoration are comparable to painted 'Habur Ware' pots, some of which contained similar bronze filter tips²⁶. The function of the small ring-based pots as vessels from which beer was drunk has been confirmed by residue analyses (see below chapter "Functional analysis").

Type 3a: Squat small jar (gestauchte Topfflasche) (Plate 2)

Size and capacity similar to Type 3, but with a reduced height and more globular or squat body.

Type 4: Small jug with trefoil spout (Kleine Kleeblattkanne) (Plate 3)

Height 9–13 cm; rim diameter 6.6–7.8 cm; capacity ca. 0.5 l.

Small jug with oval to globular body, short neck, pinched rim, vertical handle from rim to shoulder, and round base. Several examples were found in a set with small stands (three sets in House 23-S, main room 11)²⁷. Due to their form, capacity and textual sources (see below chapter "Functional analysis") we interpret them as jugs for serving liquids, especially for pouring wine into small goblets.

Type 5: Cup with vertical handle (Schöpfbecher) (Plate 3)

Height 9.3–14.3 cm; rim diameter: 7.8–16 cm; capacity ca. 0.5 l.

Deep cup with wide opening, rounded rim, vertical handle from rim to maximum diameter. The base is slightly convex. Some examples are fairly skew. The fabric and external surface are quite rough and less fine than table ware. Because one example was found between four large storage jars in storage room 6 of House 20-N, we interpret it as a scoop or ladle.

Type 6: Small jug (Kleiner Krug) (Plate 4)

Height 12–16 cm; rim diameter 8–9 cm; capacity ca. 0.5 l.

Small jug with cylindrical neck, pinched or thickened rim, oval body and with flat or ring base. The vertical handle runs from rim to shoulder.

Type 7: Small bowl (Napf) (Plate 4)

Height 4–6 cm; rim diameter 10.6–13 cm; capacity 0.3–0.4 l.

Small hemispherical to flat vessel with simple, pinched rim and round base. Several bowls belong to the standard inventory of the houses. They were found in areas of food preparation and consumption, associated with cooking pots and large beer vats. One example was used as a lid of Type 3 vessel. In storage room 43 of House 32 three bowls were stored one inside the other. A multi-functional use of the bowls is evident.

Type 8: Small plate (Kleine Schale) (Plate 5)

Height 3–5.4 cm; rim diameter 13–16 cm; capacity ca. 0.3 l.

Small plate or dish with thickened straight or bevelled rim and slightly concave flat base. They are much more rarely attested than the larger plates (Type 10).

Type 9: Small sieve (Kleines Sieb) (Plate 5)

Height 6.4–7.7 cm; rim diameter 10–12 cm; capacity ca. 0.3 l.

Small hemispherical bowl with thickened flat, round or curving rim and round base, sometimes with a ledge handle. They have circular or rectangular perforations of different sizes, dependent on the tool used to make them. Due to their small size, the strainers fit only the openings of bottles or small to medium size jars.

Type 10: Large plate (Große Schale / großer Teller) (Plate 6)

Height 9.6–13 cm; rim diameter 28–34 cm; capacity 1–2 l.

Large plate with thickened bevelled or straight rim and ring base (rarely with 3 feet). The fairly thick wall varies from straight to slightly concave. Several large plates belong to the inventory of every house. They were found in areas of food preparation and consumption. Two examples from House 34 and 20-N still contained the shells of the freshwater mussel (*Unio tigridis*), a usual foodstuff in Bazi. Because they show no signs of wear inside, they were probably used for arranging and serving food.

²⁶ Mallowan 1937, 151 Taf. XIV C; recent excavations at Chagar Bazar have brought to light more examples of graves which contained Habur jars with filter tips inside them (McMahon 2009, 245 Pl. 1, Tomb 4. Pl. 6, Tomb 39. Pl. 7, Tomb 11).

²⁷ Otto 2006a, 98 Abb. 46, 3 a. b.

Type 11: Medium jug with trefoil spout (Große Kleeblattkanne) (Plate 7)

Height 24–31 cm; rim diameter 9–10 cm; capacity ca. 4.5 l.

Ovoid jug with short neck, pouring spout, round base and vertical handle running from rim to shoulder. Some of the jugs were found associated with stands (with or without openings) and in consumption areas. The jugs (like the smaller ones of Type 4) are perfectly designed to pour liquids into smaller receptacles. Residue analysis indicates that they were used for pouring or serving wine and beer²⁸.

Type 12: Medium jar (Mittelgroße Flasche mit Standring) (Plate 9)

Height 20–28 cm; rim diameter 7–10 cm; capacity ca. 1.2–3.5 l.

Oval jar with concave neck and ring base. They are much rarer than the jugs with round bases (Type 13).

Type 13: Medium jug (Mittelgroßer Krug / mittelgroße Flasche) (Plate 9)

Height 28–45 cm; rim diameter ca. 10 cm; capacity ca. 5–20 l.

Jug with ovoid or globular body, cylindrical neck, round thickened rim and round base. Many examples have a single vertical handle which is attached to the shoulder. These jugs are very common and occur in every house. In several storage rooms on ground floor or first floor level up to 20 similar jugs were stored. Associated clay stoppers indicate that they served for the storage of liquids, possibly wine, beer or oil (residue analysis is in progress).

Type 14: Pilgrim flask (Pilgerflasche) (Plate 10)

Height 20–50 cm; rim diameter ca. 5–10.5 cm; capacity 2–34 l.

Pilgrim flasks occur in a small and a large variant: the large one is more common. The globular body is composed from two hemispherical wheel-made bowls placed rim to rim and luted together. A hole was cut through the joined rims, into which the cylindrical neck with a thickened rim was attached. A single handle was added to the shoulder. The fabric is remarkably fine, dense, well fired and less porous than the clay of the other vessels. Detailed studies of similar pilgrim flasks of the Middle Bronze Age have shown that they were used as containers for the transportation of wine²⁹ and probably originated in the area of the Upper Syrian Euphrates, including besides others Carchemish and Tall Bazi³⁰.

Type 15: Large deep bowl (Schüssel) (Plate 10)

Height 15–23 cm; rim diameter 27–40 cm; capacity ca. 12 l.

Hemispherical large bowl with wide opening, thickened rim and base ring, sometimes with a central perforation in the base. This type is less frequent than the somewhat similar Type 16. The insides of the bowls show distinct use traces. A complete example in House 1, Room 4 had the hole covered with a sherd and contained gray ashy material, which has not yet been analysed.

Type 16: Large deep bowl with incurving rim (Mittelgroßer Topf) (Plate 11)

Height 25–37 cm; rim diameter 28–45 cm; capacity ca. 12–30 l.

These pots have a wide opening that is narrower than the maximum diameter of the vessel body. They have thickened, double-profiled rims, high shoulders, and ring bases. Some examples show two vertical handles running from rim to shoulder and a few rare examples have two handles and a horizontal tubular spout. The inside surface is often covered with a thick deposit (sinter). Chemical analyses of these deposits which in two cases identified starch residues suggest a connection with water and grain. This is further strengthened by the fact that they were often found in areas of food preparation.

Type 17: Cooking pot (Kochtopf) (Plate 12)

Height 9–27 cm; rim diameter 12–29 cm; capacity 1.5–4 l.

Squat pot with wide, slightly inturned opening, thickened rim and round base. The pot is handmade, the fabric very coarsely tempered, the outside burnished. The lower part of the outside is blackened from fire, the inside often shows recognizable use traces. From many ethnographic parallels it is evident that they were used for cooking. Some pots of the 'Weststadt' still contained the remains of meals, some were associated with firedogs or lay near the hearth. When they were not in use, they were stored bottom-up. In several houses a cooking pot lay near the house altar and may have served 'to nourish' the ancestors.

²⁸ In Otto 2006a, 96 one tartrate-positive analysis was mentioned. Meanwhile more samples have been analyzed which tested to be positive in tartrate and oxalate, as well.

²⁹ Gates 1988.

Type 18: Large jar (Große Flasche) (Plate 12)

Height 45–70 cm; rim diameter 13–26 cm; capacity 40–60 l.

Large round bodied jar with narrow mouth, thickened, outturning rim, short neck, and round base.

Type 19: Large vat with/without two handles (Großer Topf) (Plate 13)

Height 40–56 cm; rim diameter 46–62 cm; capacity ca. 80 l.

Form similar to Type 16, but larger. The thickened rim is flat on the upper side. The position of the vat (often near the entrance), the wide opening, the large capacity, the sinter inside and the fact that it was easy to be moved and cleaned thanks to the handles, show that at least some of them must have served as water containers³¹.

Type 20: Large vat with perforation in the base (Großer Topf mit Lochboden) (Plate 14)

Height 50–64 cm; rim diameter 55–78 cm; capacity ca. 80–115 l.

Globular rounded or conical body (with imprints of cords (see below), wide opening with ledge rim, round base with central perforation. Rare examples are decorated with comb-incised bands and wavy lines. Because it was often found associated with the beer vat (Type 22) and large storage jars (Type 21), it must have been part of the brewing set and residue analyses showed deposits of beerstone (oxalate)³².

Type 21: Large storage jar (Großes Vorratsgefäß) (Plate 15)

Height 60–114 cm; rim diameter 20–32 cm; capacity ca. 120–180 l.

Ovoid body, relatively narrow opening with considerably thickened rim and narrow flattish base, sometimes with a central perforation. The shoulder is nearly always comb-decorated: normally this decoration consisted of a wavy line, a zig-zag line or two superimposed zig-zag lines set between two horizontal bands. Occasionally there were two such decorative bands. Many jars bore potmarks on the rim and/or on the shoulder. Several examples still contained grain and many were found in storage rooms. One example stood beside the house altar. The result of the latest, unpublished residue analyses is that they probably served as multifunctional jars for storage and preparation of different foodstuffs.

Type 22: Large beer vat (Großes Biergefäß) (Plate 16)

Height 70–78 cm; rim diameter 68–80 cm; capacity max. 200 l.

Large vat with cylindrical body and rounded lower part. Extremely thick rim, most often flat on the upper side, attached to the outside of the jar. These huge and very heavy jars were partly sunk into the ground and often made additionally secure with mud, mudbricks and stones placed on the outside. They were fixed and could not be moved. It would have been almost impossible to have cleaned them thoroughly. Nearly every house had one such vat in the main room in a well ventilated area, most frequently near the entrance or under the staircase. Often there was a second vat in an upper storey room. For these and other reasons we suggested that these vats, the largest pottery vessels found in every household were used for brewing³³. This was proven in the framework of an interdisciplinary project between beer technologists, archaeologists and philologists³⁴. Every household in Bazi brewed its own beer, and it is now clear that the so-called brewery in Hadidi³⁵ was a similar house.

In addition to these 22 types three vessel forms should be mentioned.

Type 23: Stand (Ständer) (Plate 17)

Height 5.2–29 cm; rim diameter 6.2–31 cm.

Small to large cylindrical or biconical objects, one rim cut off and formed relatively carelessly, in some instances reworked on the wheel. There are plain examples without openings, some with one row of triangular, oval or circular openings in the walls of the stands, others with triangular openings arranged in two rows alternately pointing up or down. They were often found associated with jugs (see Types 6 and 11).

Lid (Deckel) (Plate 18)

Height 5–7.7 cm; rim diameter 10.7–13.5 cm.

Conical, flat or hemispherical objects with perforated knobs. They could have been used only to cover small jars.

³⁰ Einwag 2007; see Otto 2006a, 96.

³¹ Otto 2006a, 94 Abb. 178.

³² Zarnkow *et al.* 2006a; Zarnkow *et al.* 2006b. See now extensively Sollee 2012.

³³ See detailed discussion in Otto 2006a, 86–93.

³⁴ Preliminary reports in Zarnkow *et al.* 2006a; Zarnkow *et al.* 2006b; Zarnkow *et al.* 2011.

³⁵ Gates 1988.

*Exceptional and figurative small jars
(Sondergefäße und figürliche Gefäße)*³⁶
(Plate 18)

In a few houses were found small double jars, composed of two small jugs connected together. A variant occurs with two bulls carrying the jugs on their backs, or bulls carrying the weather god and his companion. The fragmentary figures of a lute player and another cult attendant certainly belonged to further figurative jars³⁷. Kernoi with 7 attached beakers and a spout in the form of a ram's head served to pour special liquids in a very sophisticated manner. Mobile cylindrical vessels with four wheels and a spout as a ram's head also occur in several houses. Most of these exceptional jars, all of them unique, were found near the altar of the main room and may therefore be interpreted as part of the ritual inventory of the household.

Functional analysis of the 'Weststadt' pottery

The function of a vessel can be deduced in several different ways³⁸:

- observation of primary features of the vessel itself (such as its form, size, fabric, the condition of the surface, and the presence of spouts or handles)
- examination of secondary features caused by wear during use such as rubbing,
- flaking and scratching on the inside or outside of the vessel³⁹
- identification of the contents (either preserved or derived through residue analysis)
- study of the decoration or potmarks which might point to a specific function
- analysis of the context in which the vessel was found
- ethnographic analogies and ethnoarchaeological comparisons⁴⁰
- information derived from contemporary written sources.

In the investigation of the function of the vessels found in the 'Weststadt' the contextual analysis was extremely informative: by determining the 'ideal' number, size, location and association of the different ceramic types in a house, it became clear that certain functions for the various types of vessels were more probable than others. Further refinement was achieved with the help of residue analysis, the study of the relevant texts from Emar and Munbaqa, the use of ethnographic analogies and the experience of experimental brewing of the Bazi beer on the site.

The functions of the vessels could be deduced from their positions in the houses, because many vessels were found where they were being used at the moment of the destruction. Clear exceptions are vessels which were stored in special rooms or places. Of course, the vessels could have been displaced for a multitude of reasons during the chaotic conditions at the end of the occupation of the settlement. Here again, the method of the concept of the ideal type was crucial to recognize the zones where the vessels were used. The ideal findspots of the objects also underline the different distribution of pottery used in domestic activities and special purpose vessels (such as painted and figurative jars).

Further efforts were made to define the function of the vessels by means of residue analysis. Already many analyses have given clear results concerning the consumption of grain and grain products, the storage, serving and drinking of wine and especially the brewing and consumption of beer. Further analyses are in progress.

A joint project with the TU München-Weihenstephan, Lehrstuhl für Brauerei-Technologie I, is devoted to the investigation of ancient brewing in the 'Weststadt' houses. The hypothesis that every household brewed its own beer, based on the archaeological evidence, was confirmed by residue analysis: the large vats which were present in nearly every house at the best ventilated place of the house (most often under the staircase in the main room) clearly showed by the deposits of oxalate that they were part of the beer brewing process. These conclusions were further investigated by reconstructing the process of brewing. This experiment clarified many of the steps in the rather complicated brewing process and explained the functions of the vessels and tools employed⁴¹.

The beer brewing set clearly consisted of the large beer vat (Type 22), a vat with a perforated base (Type 20) and storage jars (Type 21). Other vessels could be identified as having been used for wine by residues of tartrate. Small goblets (Type 1), jugs with trefoil spouts (Types 4 and 11) and small ring-based pots (Type 3) were used both for drinking and serving beer and wine, as our not yet published residue analyses have shown. Texts from Emar also support this conclusion as they record that „wine beakers were filled“, and that *kāsu*-goblets, *hizzi-bu*-vessels and the slightly smaller *mabharu*-vessels were used for the consumption of wine and beer during the meals at the *zuku*-festival⁴².

³⁶ Otto 2006a, 100–102 Abb. 45, 4–5.

³⁷ Otto 2001, Abb. 3. 4. 6. 7. Taf. 2. 3.

³⁸ Rice 1987, 207–243.

³⁹ Skibo 1992, 105–143.

⁴⁰ Longacre 1991.

⁴¹ See the detailed reports in Zarnkow *et al.* 2006a; Zarnkow *et al.* 2006b; Zarnkow *et al.* 2011; Otto 2006a, 86–93.

⁴² Otto 2006a, 56–57.

Characteristics and technological traits of the locally produced and of the imported vessels

The vast majority of the pottery found in the 'Weststadt' is very homogeneous in technique, fabric, surface treatment and forms and a local origin for most of the vessels can be supposed⁴³. Within the 'Weststadt' only one small pottery kiln for the production of small bowls and beakers was discovered in Room 125 north of House 24⁴⁴. Other pottery kilns must have been situated elsewhere in the lower town⁴⁵. Nearly all the pottery was formed on the fast wheel, was well made and was well fired. Only the large wide-mouthed beer vats were partly handmade and the rim was attached separately. Further exceptions are the cooking pots which were always handmade and burnished.

The lower parts of vessels were sometimes trimmed by cutting away the surplus clay with a sharp tool. The large storage jars with the comb-incised decoration (Type 21) were apparently stuck into sand during the drying process as is shown by the sandy surface of the lower third of the vessel. The lower half of the large jars and vats also bear impressions of string, that were not decorative but were evidence that string was wound round lower parts of the vessels to hold them together during the drying process, not for decoration (see Pl. 13–16).

The local pottery is always mineral-tempered, from very coarse (cooking pots) to coarse (large vats), medium-fine (medium-sized vessels) and very fine (beakers and bowls). But the fabric and the surface of even the finest vessels is not as fine and smooth as the third millennium pottery of Banat-Bazi. Very rarely vessels are chaff-tempered: these are clearly imports.

In general, the surfaces are relatively rough and not carefully treated, although they are sometimes wet-smoothed. Rare examples of jugs with red or reddish-black burnished slip are certainly imports from coastal Syria or Cyprus; their form suggests that they were containers for special liquids⁴⁶. No painted Nuzi-ware or other painted ware was found in the 'Weststadt', although a fragmentary Nuzi goblet with a dark brown and white painted design came from the temple on the citadel.

The date of the 'Weststadt' pottery

The 'Weststadt' pottery constitutes the most abundant collection of 'complete' vessels of their period. Determining the date of the collection is therefore of prime importance. Three samples of carbonized wood from Houses 17, 25 and 46 and two samples of carbonized grain from Houses 20 and 46 have been analyzed by J. Görzdorf (DAI Berlin)⁴⁷ (Table 1):

Laborbezeichnung:	Bln-5407
Probenbezeichnung:	Bz 25/30: 29
Fundort:	Haus 46, Raum e
Datierungsmaterial:	Getreide
d13C-Bestimmung:	-23,3‰
konventionelles 14C-Alter mit 1 s Vertrauensbereich:	2977 ± 35 BP
Kalibrationsintervalle (68,2 %):	1290–1280 cal BC 1270–1120 cal BC
Laborbezeichnung:	Bln-5408
Probenbezeichnung:	Bz 25/36: 35
Fundort:	Haus 20, Raum 6
Datierungsmaterial:	Getreide
d13C-Bestimmung:	-22,6‰
konventionelles 14C-Alter mit 1 s Vertrauensbereich:	3054 ± 33 BP
Kalibrationsintervalle (68,2 %):	1390–1290 cal BC 1280–1260 cal BC
Laborbezeichnung:	Bln-5409
Probenbezeichnung:	Bz 25/37: 6
Fundort:	Haus 17, Raum 1
Datierungsmaterial:	Holzkohle
d13C-Bestimmung:	-27,2‰
konventionelles 14C-Alter mit 1 s Vertrauensbereich:	2937 ± 37 BP
Kalibrationsintervalle (68,2 %):	1260–1240 cal BC 1220–1050 cal BC
Laborbezeichnung:	Bln-5410
Probenbezeichnung:	Bz 31/38: 58
Fundort:	Haus 25, Raum 4
Datierungsmaterial:	Holzkohle
d13C-Bestimmung:	-25,3‰
konventionelles 14C-Alter mit 1 s Vertrauensbereich:	2993 ± 33 BP
Kalibrationsintervalle (68,2 %):	1300–1120 cal BC
Laborbezeichnung:	Bln-5411
Probenbezeichnung:	Bz 25/31: 15
Fundort:	Haus 46, Raum b
Datierungsmaterial:	Holzkohle
d13C-Bestimmung:	-24,4‰
konventionelles 14C-Alter mit 1 s Vertrauensbereich:	2939 ± 33 BP
Kalibrationsintervalle (68,2 %):	1260–1240 cal BC 1220–1050 cal BC

Table 1 Radiocarbon analysis of carbonized grain and wood from the 'Weststadt' houses (J. Görzdorf, DAI Berlin).

الجدول ١ تحليل الكربون المشع للحبوب والأخشاب المتفحمة المكتشفة في منازل "المدينة الغربية" (ي. غورزدورف، معهد الآثار الألماني، برلين).

⁴³ Precise percentages or numbers of vessels cannot be given in this paper because the work on the 'Weststadt' pottery is not yet completed.

⁴⁴ Otto 2006a, 263–264 Abb. 175.

⁴⁵ Two other Late Bronze Age pottery kilns were discovered in the Nordstadt; for the one at the foot of the citadel see Einwag – Otto 1996, 23 Taf. 5 d.

⁴⁶ Otto 2006a, 100–102 Abb. 45,2.

⁴⁷ Görzdorf in Einwag – Otto 2006.

A date within the 13th century seems to be indicated by the radiocarbon dates. However, because of the apparent discrepancy with the dates proposed for other sites (see below), we are sceptical about the accuracy of these dates. More samples are presently in course of investigation in different laboratories⁴⁸.

The conventional archaeological relative dating by comparisons with the pottery from other sites leads to different results. The material from the houses of the ‘Weststadt’ of Bazi has close parallels in many sites of the Euphrates region. Closely comparable pottery comes from the Tablet Building at Tall Hadidi⁴⁹, from an upper level at Emar⁵⁰, the upper level at Munbaqa⁵¹, an upper level at Tall Qitar⁵², from *La maison brûlée* at Shiukh Foqani⁵³, and from a burnt level in period II at Umm el-Marra⁵⁴. In the majority of these settlements the material comes from a burnt level. However, there is little agreement about the date of these levels: the suggested time range extends from the 15th to the 13th century BC.

The ceramic assemblage which is most closely similar to the material from the ‘Weststadt’ was found in the Tablet Building at Tall Hadidi and was dated to the Late Bronze Age I or 15th century BC by R. Dornemann by means of radiocarbon dates, comparisons to other, mainly Levantine sites and an estimated dating of the tablets⁵⁵. Because R. Dornemann’s article about the Hadidi pottery constituted the best presentation of Late Bronze age ceramic vessels of the region until recently, most scholars have followed his proposed dating, for example T. L. McClellan dated the material from Tall Qitar and from Tall Banat to the 15th century⁵⁶. In Tall Qitar a legal document of the Syro-Hittite type was found in Area X, House 12. It bears the impression of a Syro-Hittite cylinder seal which belonged to the local priestess of the Weather-god and is certainly to be dated to the late 14th or 13th century BC⁵⁷. The excavators stressed that the tablet was found “considerably above the absolute level of the storage jars in neighbouring Room 1” and therefore may not belong to the level of the building. They explained the fact that the tablet lay clearly lower than the west wall of House 12 by proposing that the wall served as a terrace wall⁵⁸. There is, however, no clear evidence for an overlying level in the preliminary reports and most of the groundplans were already visible at the surface. Perhaps a slightly later date in the late 14th or even 13th century should be considered for this level at Qitar.

The same may be true for the proposed dating of the houses found in Banat, which lie immediately to the north of Tall Bazi⁵⁹. They are part of the same settlement as the ‘Weststadt’ of Bazi, the houses have similar ground plans and the pottery is identical to that found in the ‘Weststadt’ houses⁶⁰.

When in September 2007 the level of the Tishreen lake sank about 1.5 m, we could see that the water had washed away the overlying deposits and revealed dozens of houses in the ‘Nordstadt’ of Bazi and in Banat. We had two days to document them before the water level rose again. The houses (their building technique, size, ground plan, and installations) and their pottery correspond exactly to the examples from the ‘Weststadt’. It is therefore very likely that the date of the latest house level at Banat is the same as the date of the Bazi houses.

The burnt houses at Umm el-Marra and Shiukh Foqani have been dated tentatively by their excavators to the 14th century according to ¹⁴C-dates, and the excavators have drawn attention to the fact that this dating is later than the 15th-century date previously proposed for similar material⁶¹.

In the later levels at Emar there are several buildings with material comparable to the ‘Weststadt’ houses⁶². The members of the French mission at Emar have recognised the disturbing discrepancy between their dating and that proposed for comparable pottery and glyptic material from Hadidi. As Dominique Beyer has remarked, the Hadidi tablets seem to be contemporary to the last generation attested at Emar, and the differences might be due to the calibration of the radiocarbon dates⁶³.

⁴⁸ Since this article was written in 2007, more samples have been analyzed in three different laboratories. They give earlier dates, which will be published in a forthcoming volume on the Late Bronze Age in North Syria (see Note 66).

⁴⁹ Dornemann 1980, 1981.

⁵⁰ Finkbeiner – Sakal 2003, 18–31.

⁵¹ For three different hypothetical datings of Munbaqa see Werner 2004, 23–24.

⁵² See for example the closely related pottery from Building 151: McClellan 1986, 90. 101–105 figs. 10–12.

⁵³ Bachelot – Fales 2005, 329–367.

⁵⁴ Schwartz *et al.* 2003, 348–353 figs. 32. 33; Curvers – Schwartz 1997, 219–222 fig. 19, 3. 4. 9. 13.

⁵⁵ Dornemann 1980; Dornemann 1981.

⁵⁶ McClellan 1985; McClellan 1986; McClellan 1992. He compared the pottery of building 15 at Tall Qitar to the one from the Tablet Building at Hadidi and dated it therefore to the 15th century BC. Remark the closely related layout of Building 15 and a standard Bazi house.

⁵⁷ Adoption contract, according to line 1 sealed by a priestess of the weathergod, Sippilumshe of Til-Abnu = zipilusa tilpanu: Archi 1993, 203–206.

⁵⁸ Culican – McClellan 1984, 41–42 pl. 8.

⁵⁹ Since the beginning of our combined efforts at the site Banat-Bazi (EBA) or Bazi-Banat (LBA) we have benefitted greatly from stimulating discussions with our dear friends Tom McClellan and Anne Porter about the various interpretations of the evidence from these excavations. For that we give our heartfelt thanks as well as for their good neighbourly friendship.

⁶⁰ Preliminary report: McClellan 1991.

⁶¹ Schwartz *et al.* 2003, 352 Table 2; Bachelot – Fales 2005, 329–331.

⁶² E.g. from the building in square 72–73/52–53; Finkbeiner – Sakal 2003, 25–31 figs. 4–6. 8.

⁶³ Beyer 2001, 3–4.

At the moment, it is too early to decide whether the destruction horizons in the above-mentioned sites should be attributed to several different events or whether they were the result of one major event which struck the whole area⁶⁴. The results of several recent excavations cast doubt on a suggested collapse in the 15th century. It is still an open question whether the various burnt horizons were caused by a historical event such as the Hittite expansion in the middle of the 14th century or some other historical development in the 13th century, by a slow deterioration of the settlements brought about by internal, perhaps socio-economic problems or by some other circumstances.

There are, however, strong arguments for attributing the burning of the 'Weststadt' of Bazi and probably also of several other sites to a human enemy approaching from outside the settlement, and not to internal misfortunes such as increasing impoverishment and social tensions within the settlements. The many weapons and precious objects left in the houses indicate that the violent destruction of the 'Weststadt' was not foreseen. Signs of plundering in the houses before the burning speak in favour of an enemy having destroyed the whole settlement. Furthermore the temple on the citadel of Bazi was violently destroyed by fire at the same time. The former inhabitants completely disappeared and the whole settlement was abandoned until the Roman period. In its latest phase the 'Weststadt' was a rich, flourishing settlement, and the changes in the use of the houses can plausi-

bly be explained by the natural processes that take place in any functioning community such as births, deaths, marriages, inheritances, property sales, bankruptcy, and affluence necessitating or allowing changes in the compositions of the households⁶⁵.

This paper has drawn attention to some of the problems in dating the Late Bronze Age occupations and abandonments in the Upper Syrian Euphrates region. In particular a reassessment of the 15th century BC date suggested for the Tablet Building at Hadidi is desirable. A satisfactory interpretation of the archaeological record of this period will only be achieved when the archaeological evidence is combined with analyses of the historical sources and further scientific dating of the sites. Then the date or dates of the destructions will become evident.⁶⁶

⁶⁴ McClellan sees a slow decline of the sites in inland Syria which began already in the Middle Bronze Age and lasted throughout the Late Bronze Age. His reasons for this assumption are the early datings of Hadidi, Qitar and Banat, whose collapses he dates to the 15th century, whereas he accepts a date at the end of the 13th century for the collapses of Emar, Faqus and Tall Fray: McClellan 1992, 164–173.

⁶⁵ Otto 2006a, 273–275.

⁶⁶ Members of the archaeological mission at Emar, Ekalte, Umm el-Marra, El-Qitar and Bazi discussed these discrepancies during a workshop in Mainz in 2012. Many of the above mentioned problems were solved during this meeting. The results are presently prepared for publication in a volume titled: "The Chronology of the Late Bronze Age in the Upper Syrian Euphrates Valley: The Archaeological View".

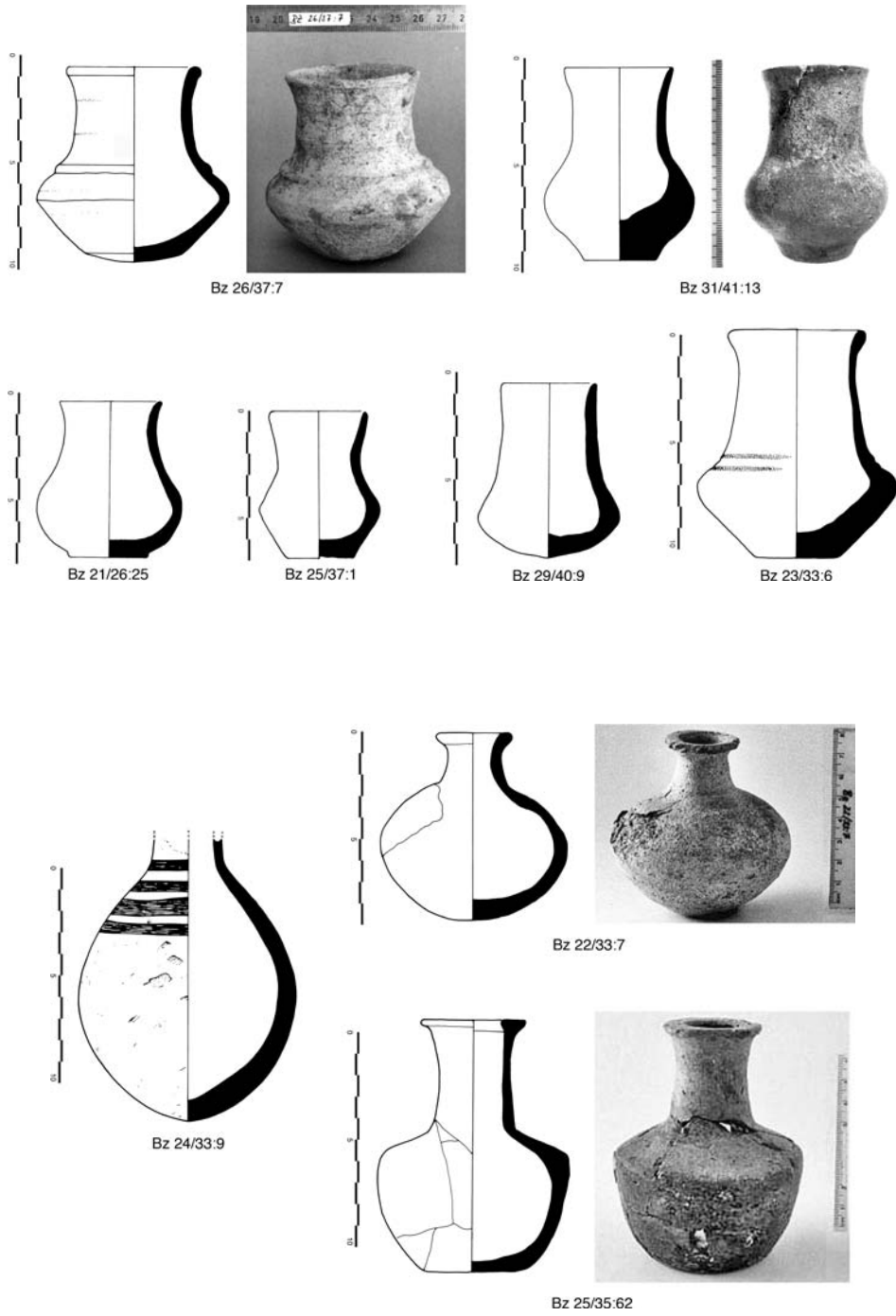

Plate 1 Type 1 and Type 2.

اللوحة ١ النمط 1 والنمط 2.

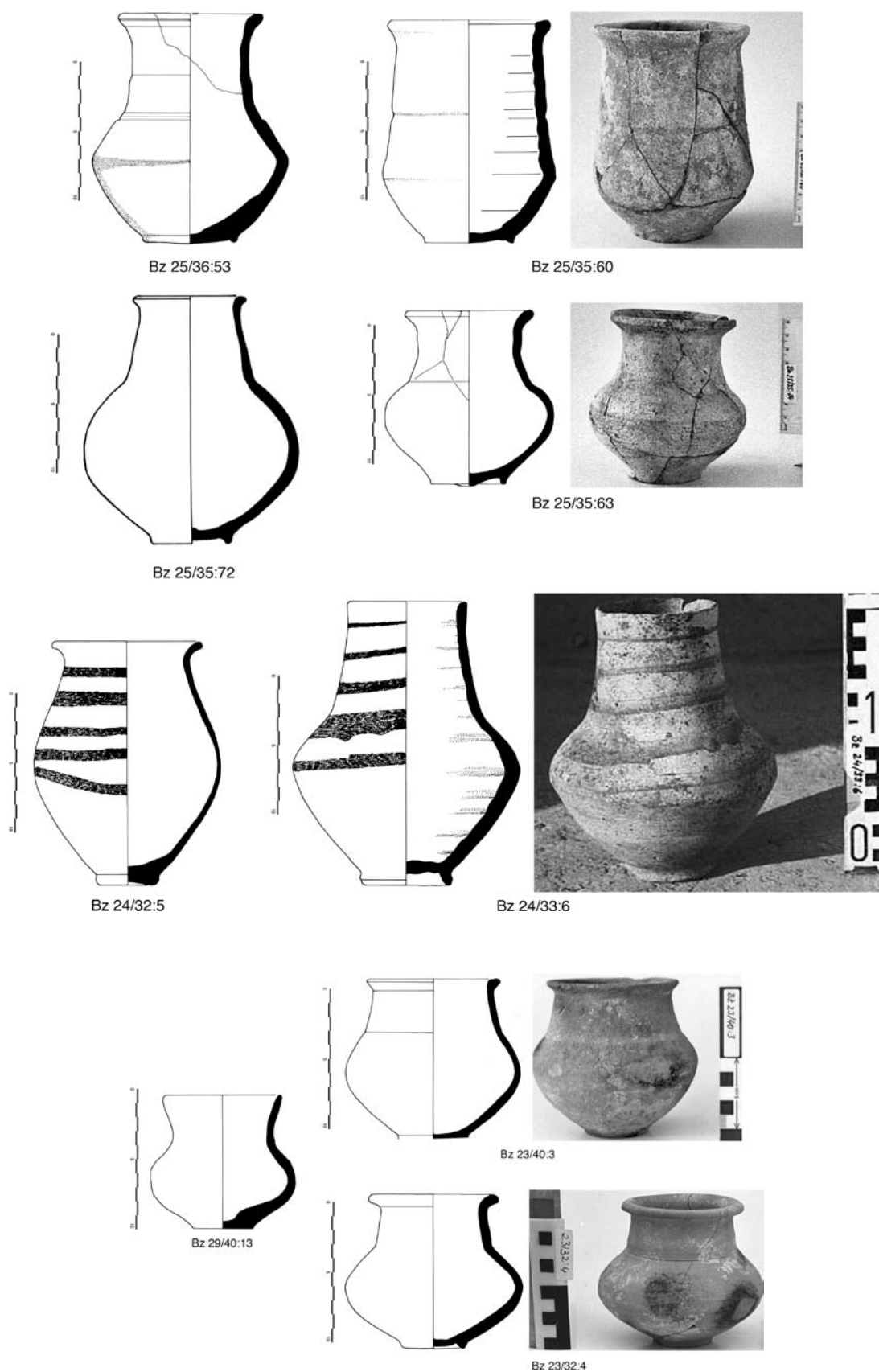

Plate 2 Type 3 and Type 3a.

اللوحة ٢ النمط 3 والنمط 3a.

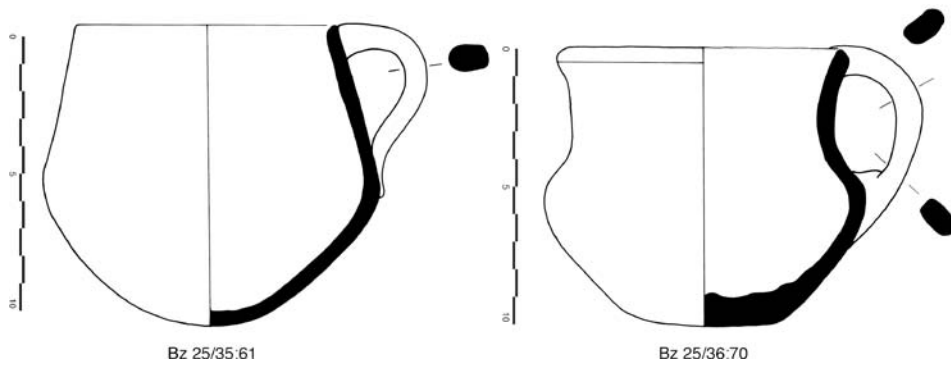
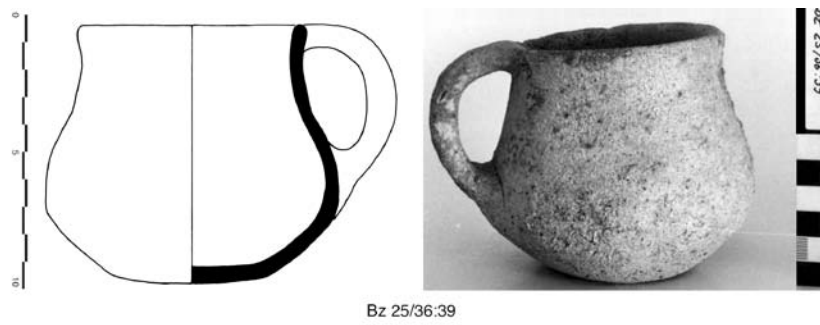
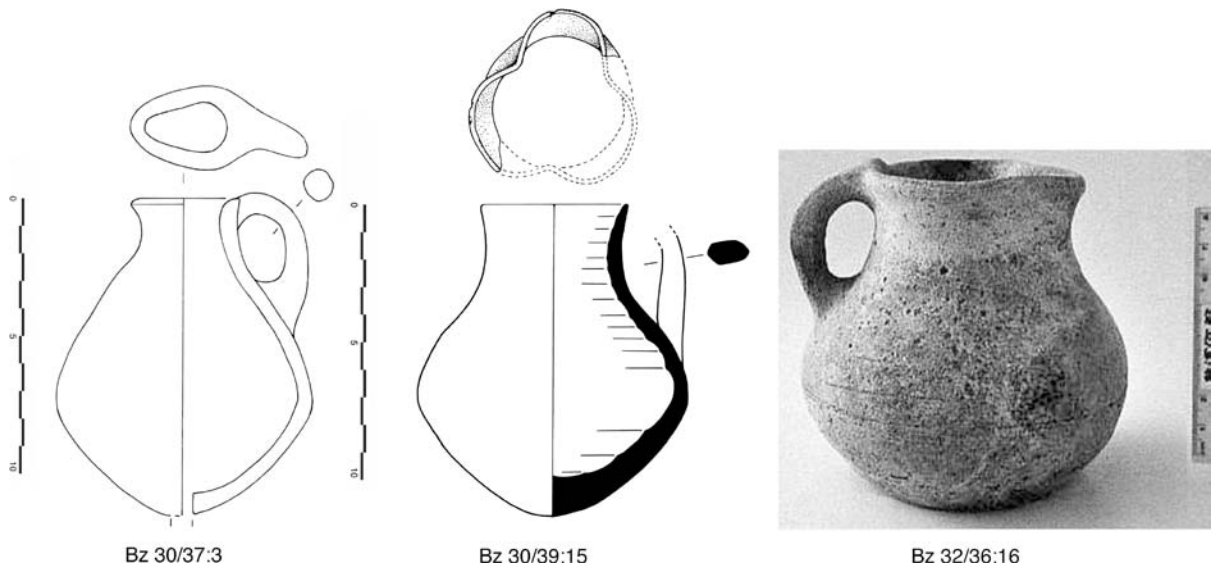

Plate 3 Type 4 and Type 5.

اللوحة ٣ النمط 4 والنمط 5.

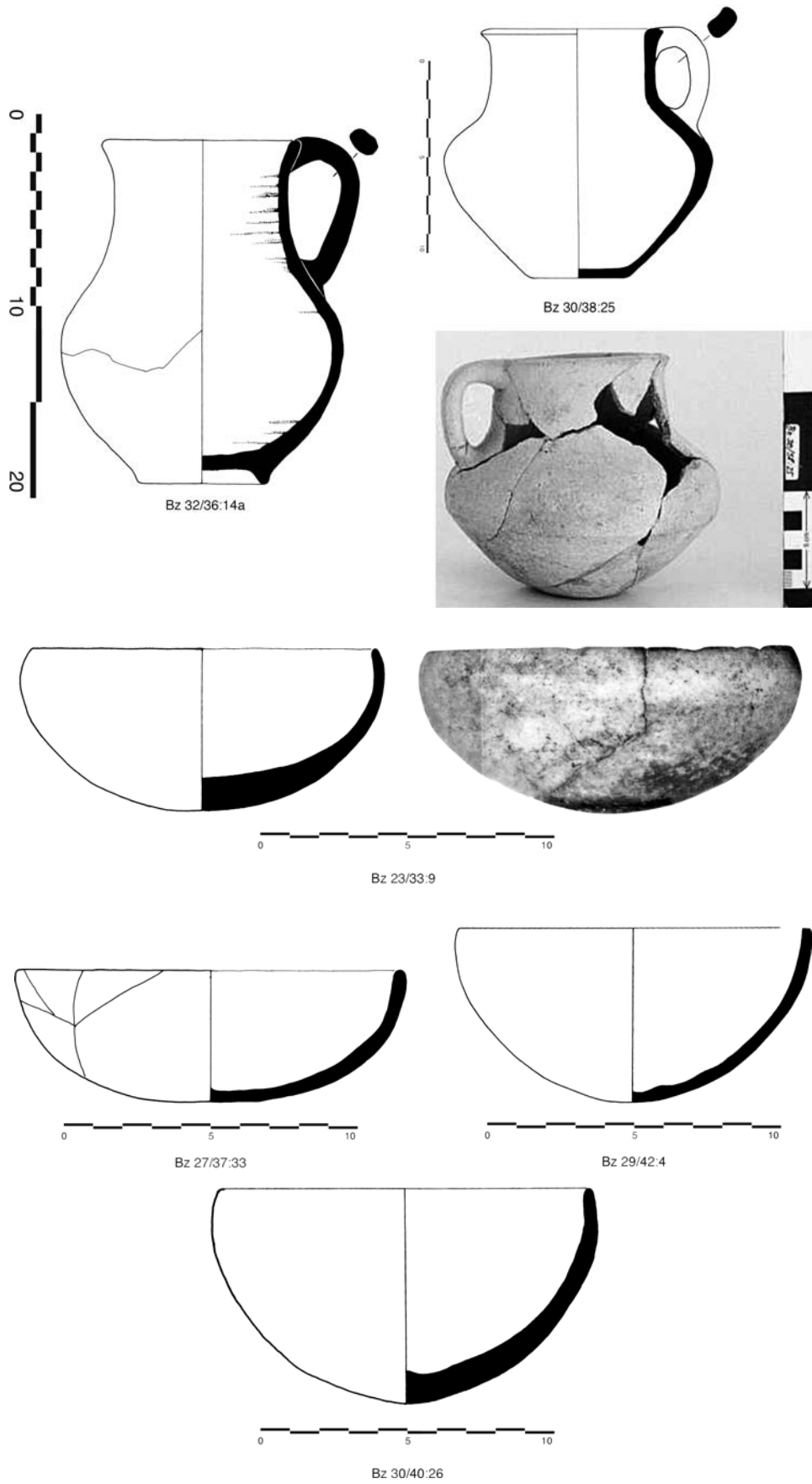
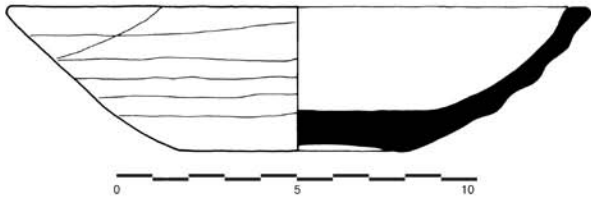
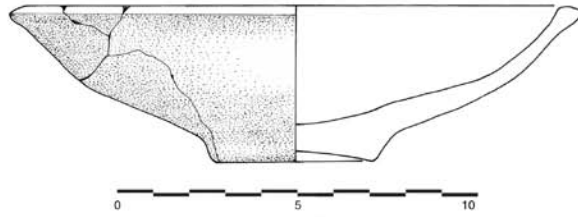

Plate 4 Type 6 and Type 7.

اللوحة ٤ النمط 6 والنمط 7.



Bz 25/35:67



Bz 26/34:16

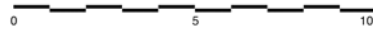
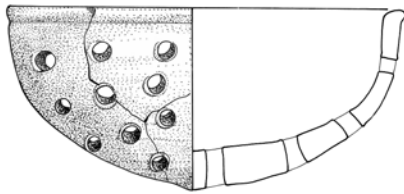

Bz 26/34:18

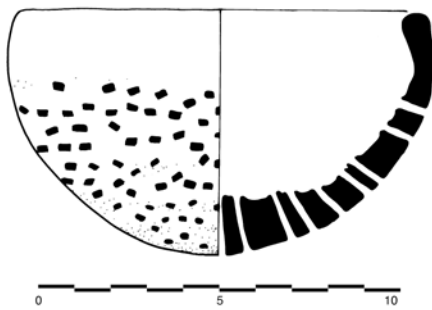

Bz 24/33:17

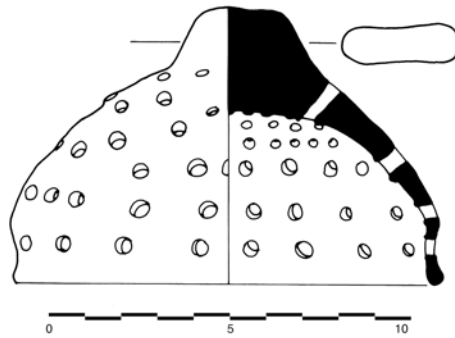

Bz 24/35:13

Plate 5 Type 8 and Type 9.

اللوحة ٥ النمط 8 والنمط 9.

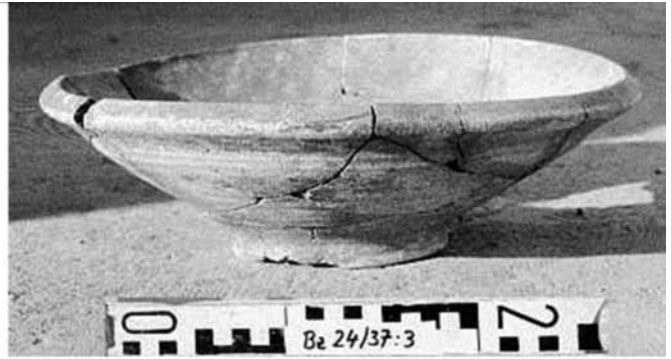
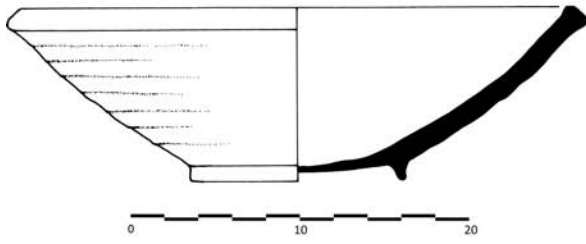

Bz 24/37:3

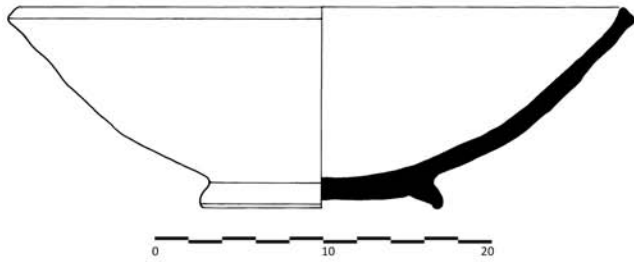

Bz 25/37:16

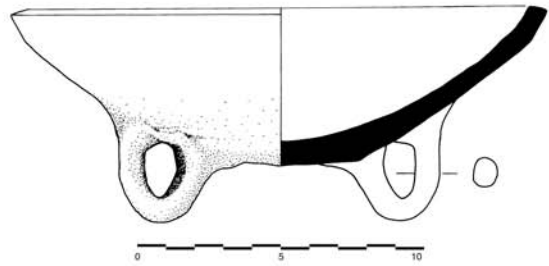

Bz 26/36:29

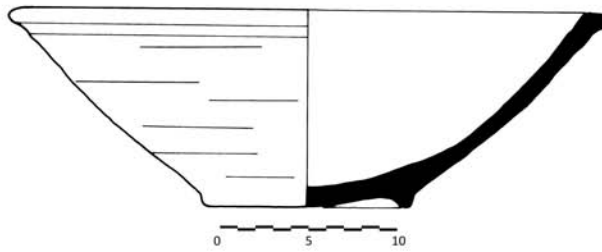

Bz 27/35:22

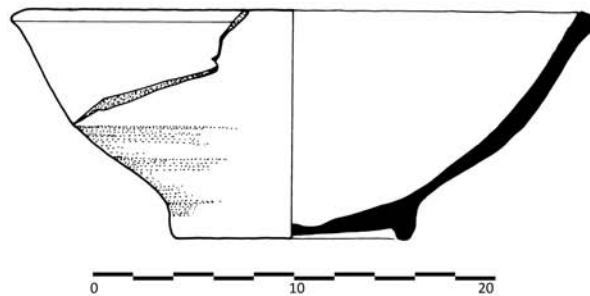

Bz 32/36:21c

Plate 6 Type 10.

اللوحة ٦ النمط 10.

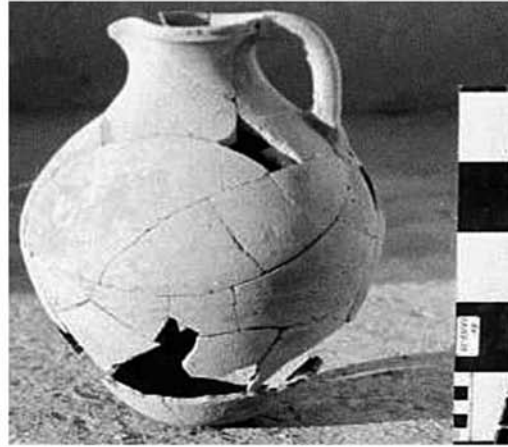
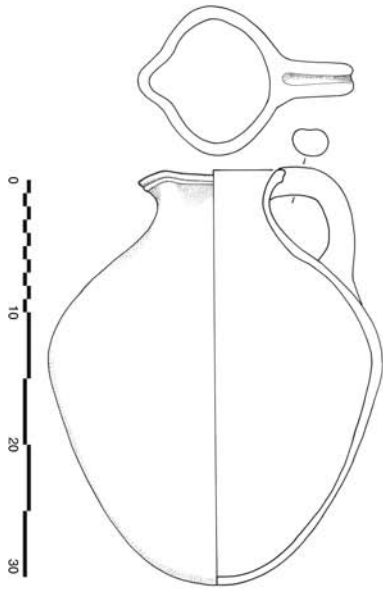

Bz 27/37:39

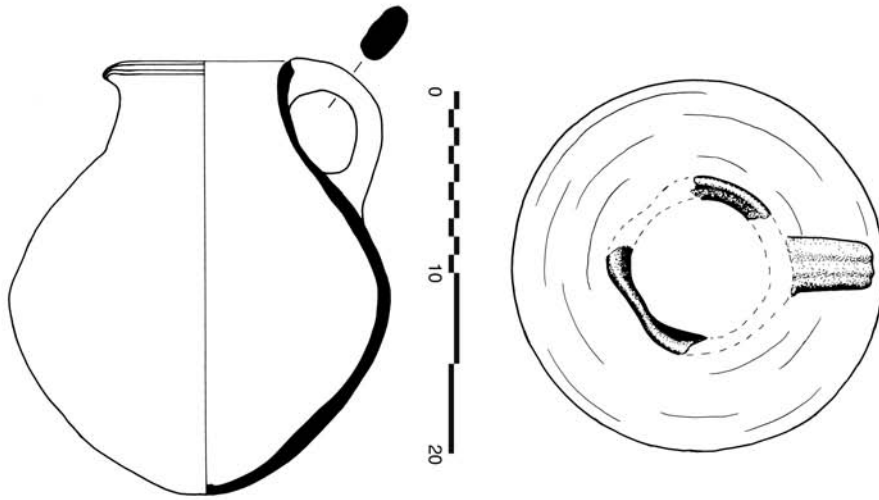

Bz 25/35:59

Plate 7 Type 11.

اللوحة ٧ النمط 11.

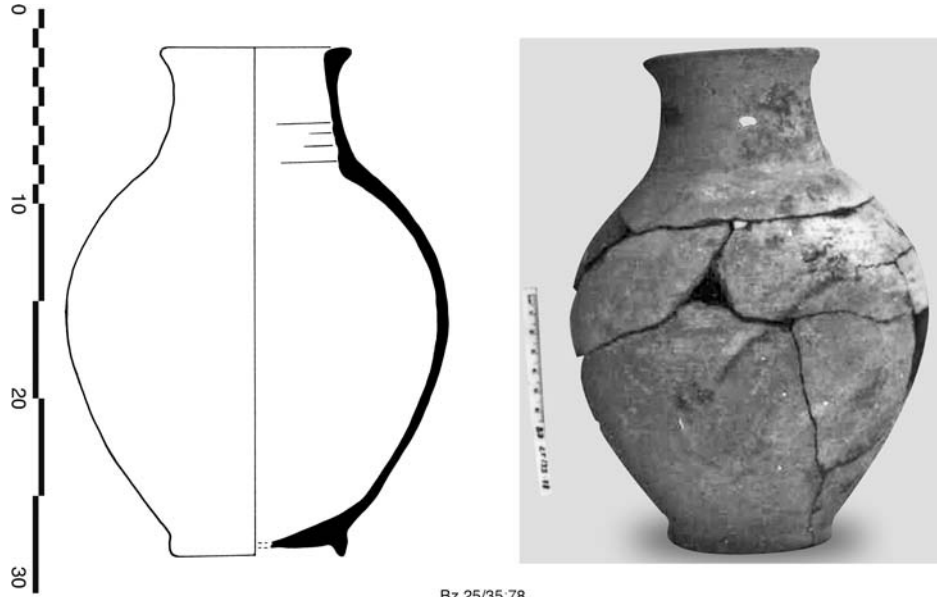

Bz 25/35.78

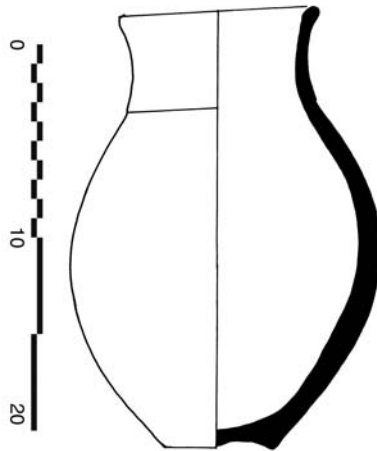

(24/27SO-22/27SW, G3)

Plate 8 Type 12.

اللوحة ٨ النمط 12.

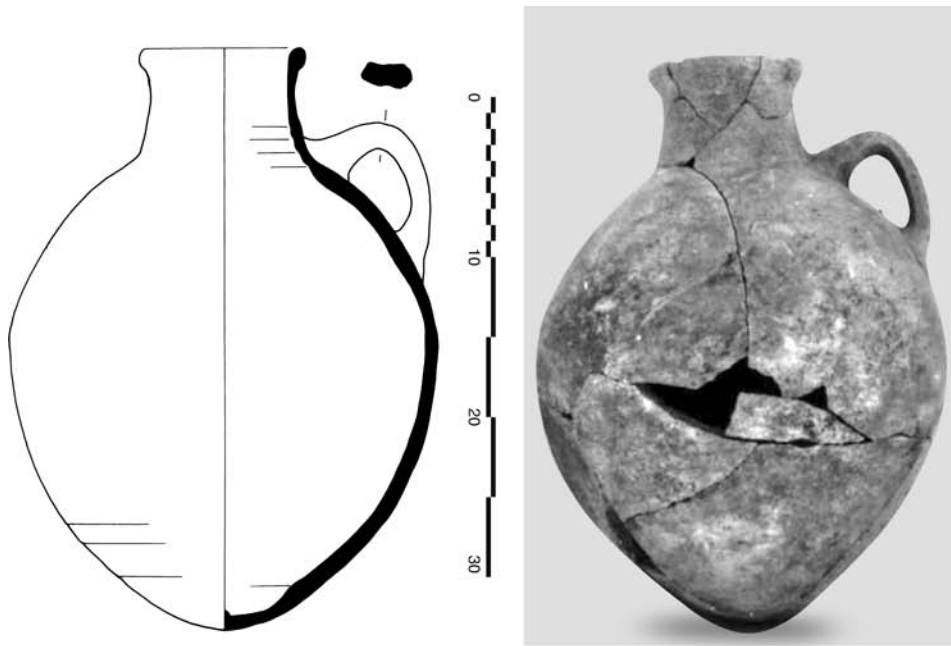

Bz 25/35:79

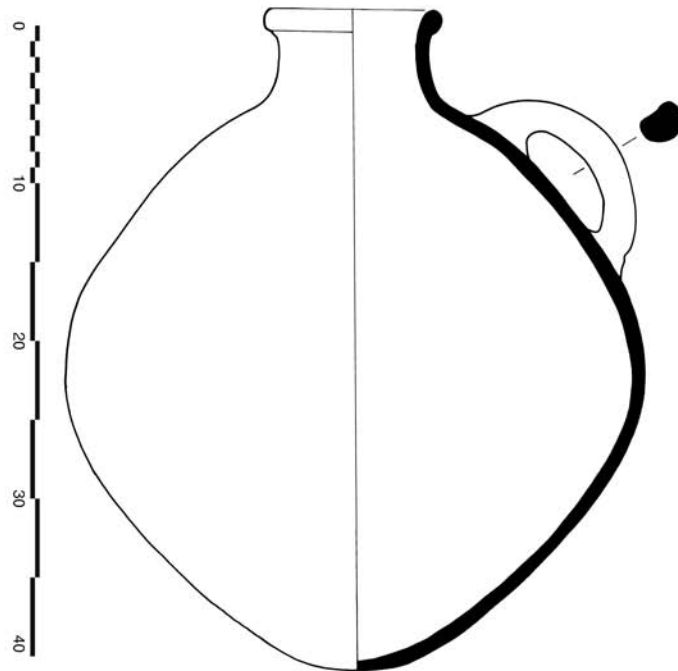

Bz 24/33:22

Plate 9 Type 13.

اللوحة ٩ النمط 13.

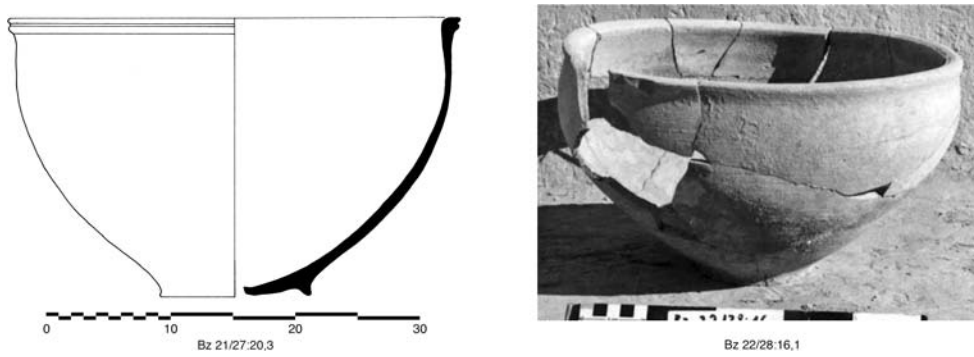
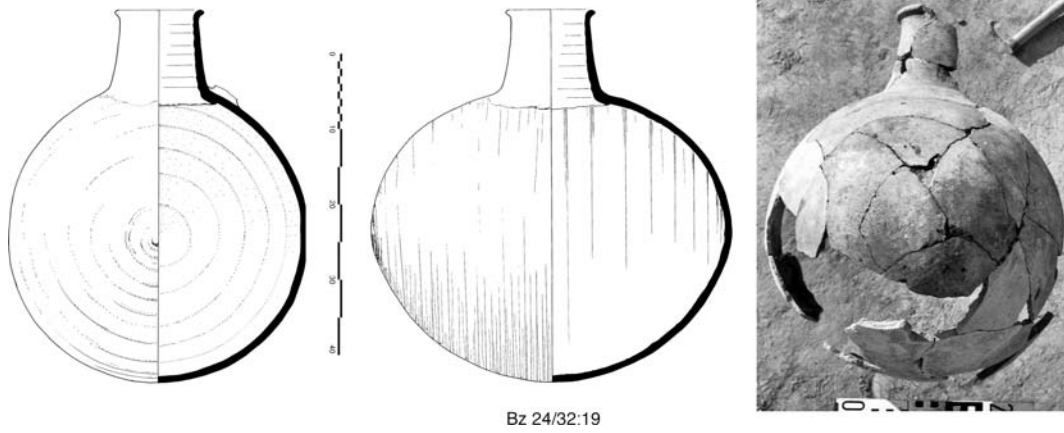
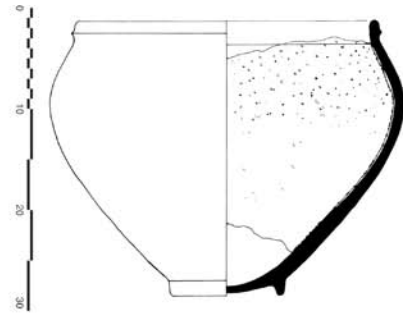
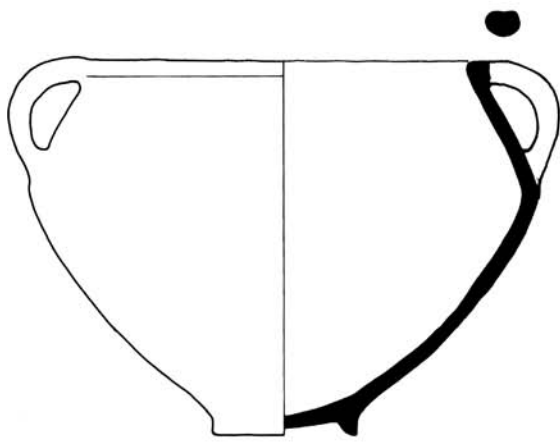

Plate 10 Type 14 and Type 15.

اللوحة ١٠ النمط ١٤ والنمط ١٥.



Bz 27/36:23



Bz 22/31:10



Bz 26/34:23,4

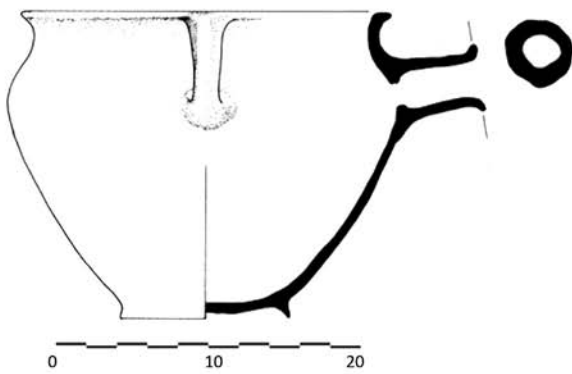

Bz 24/33:40,13



Bz 25/29:19

Plate 11 Type 16.

اللوحة ١١ النمط 16.

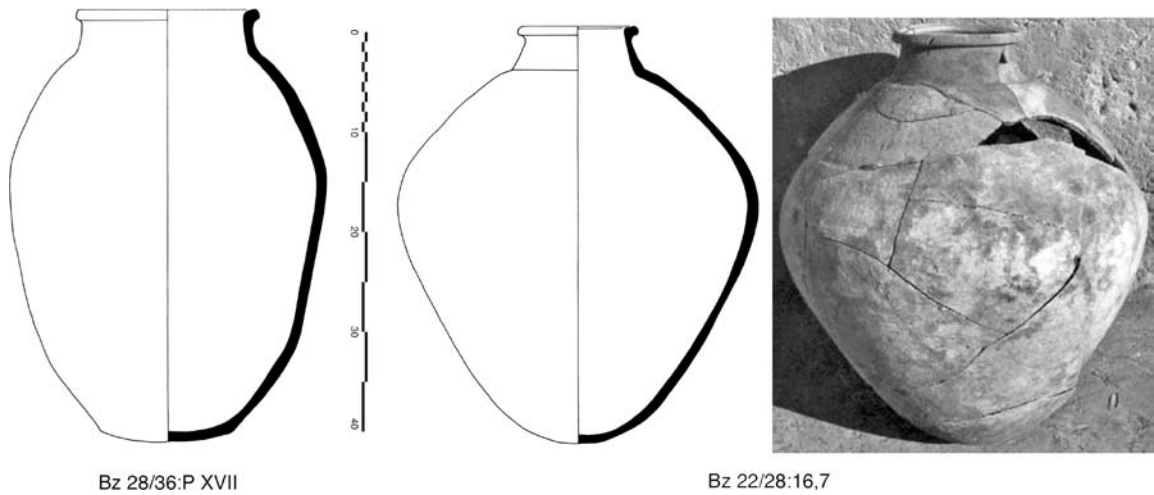
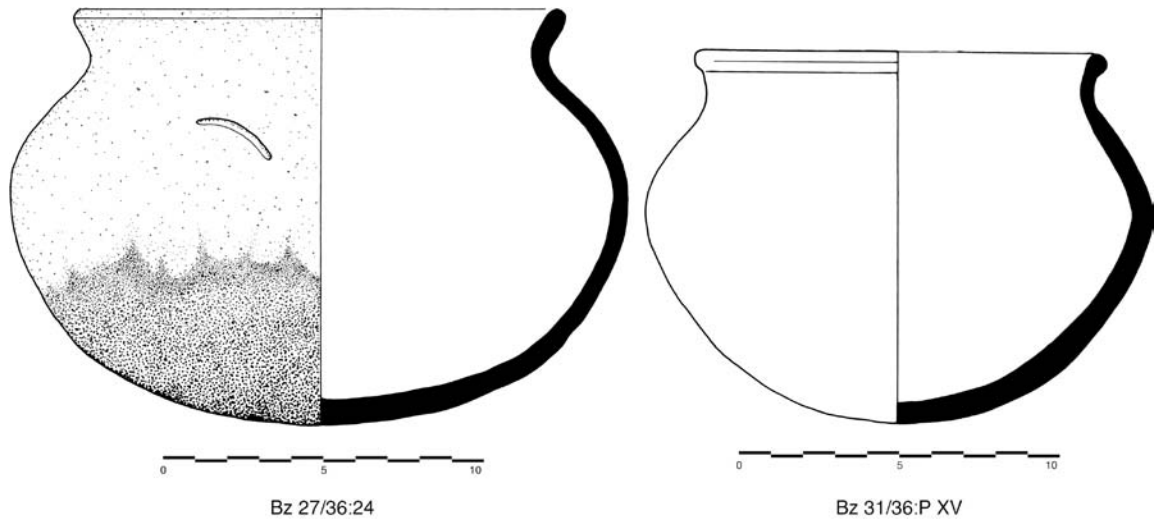
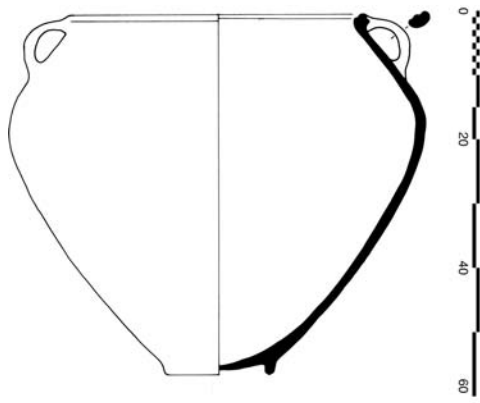
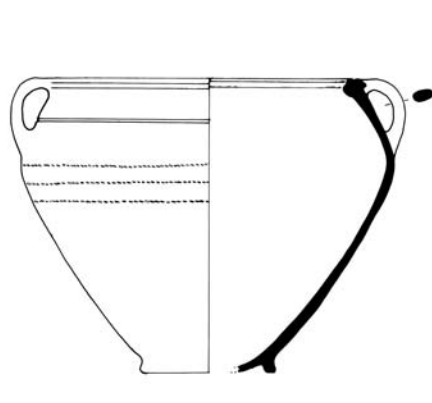

Plate 12 Type 17 and 18.

اللوحة ١٢ النمط 17 والنمط 18.



Bz 28/36:P XIII



Bz 24/37:P V

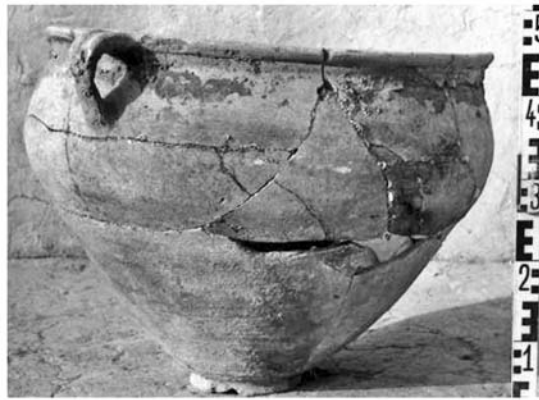

Bz 25/36:43

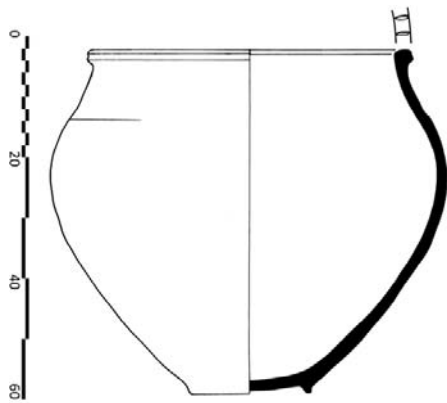
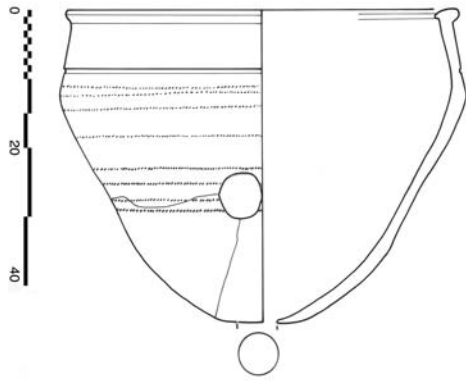
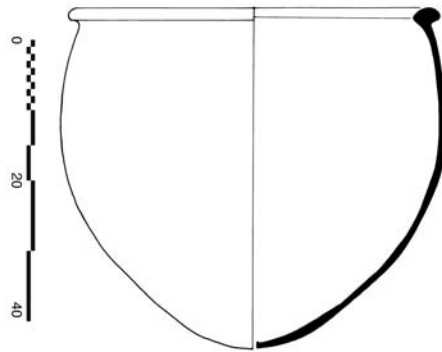

Plate 13 Type 19.

اللوحة ١٣ النمط 19.



Bz 27/36:15



Bz 25/36:75

Plate 14 Type 20.

اللوحة ١٤ النمط 20.

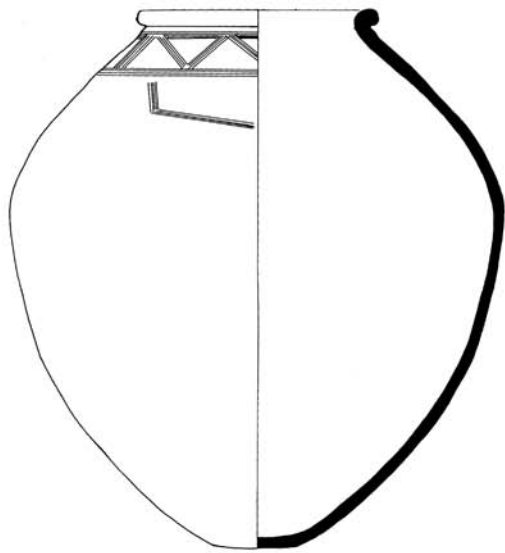

Bz 21/26:81,20

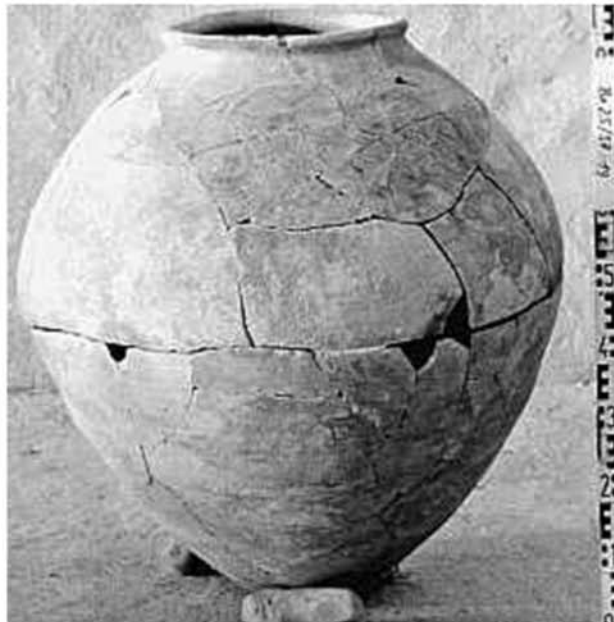
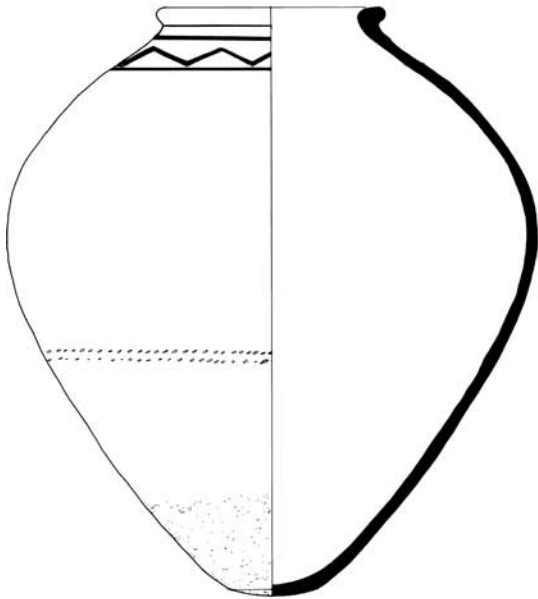

Bz 25/37:19

Plate 15 Type 21.

اللوحة ١٥ النمط 21.

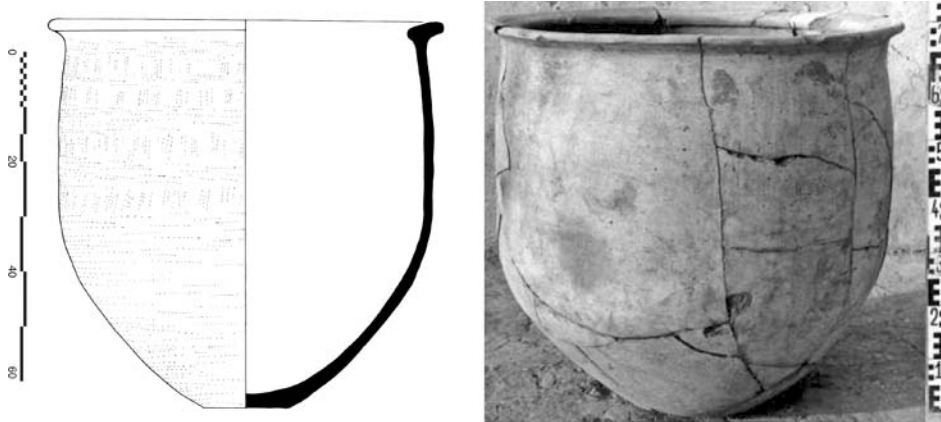

Bz 25/37:14

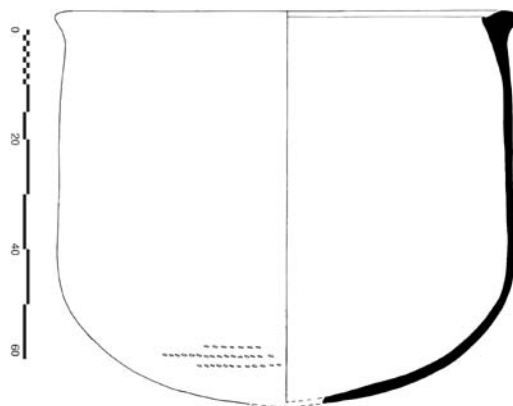

Bz 22/26NW

Plate 16 Type 22.

اللوحة ١٦ النمط 22.

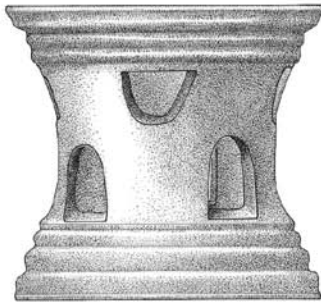
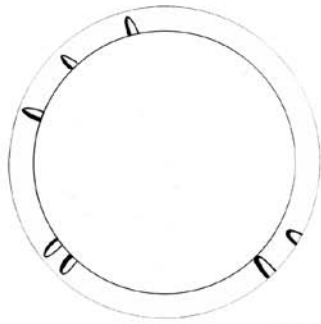

0 10 20

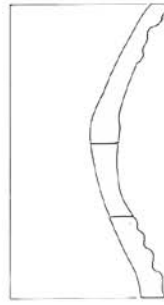

Bz 21/35:5

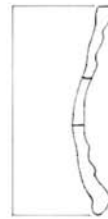
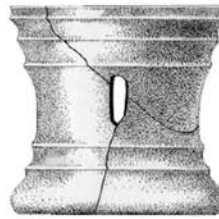

0 10

Bz 25/30:57

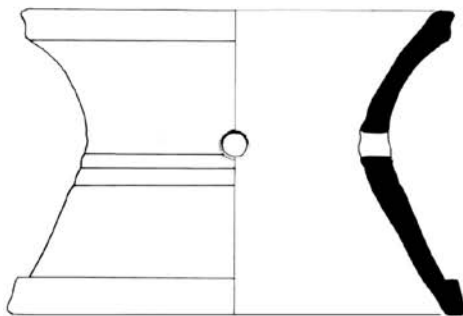

0 10 20

Bz 23/41:11

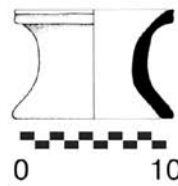

Bz 30/38:7

Plate 17 Type 23.

اللوحة ١٧ النمط 23.

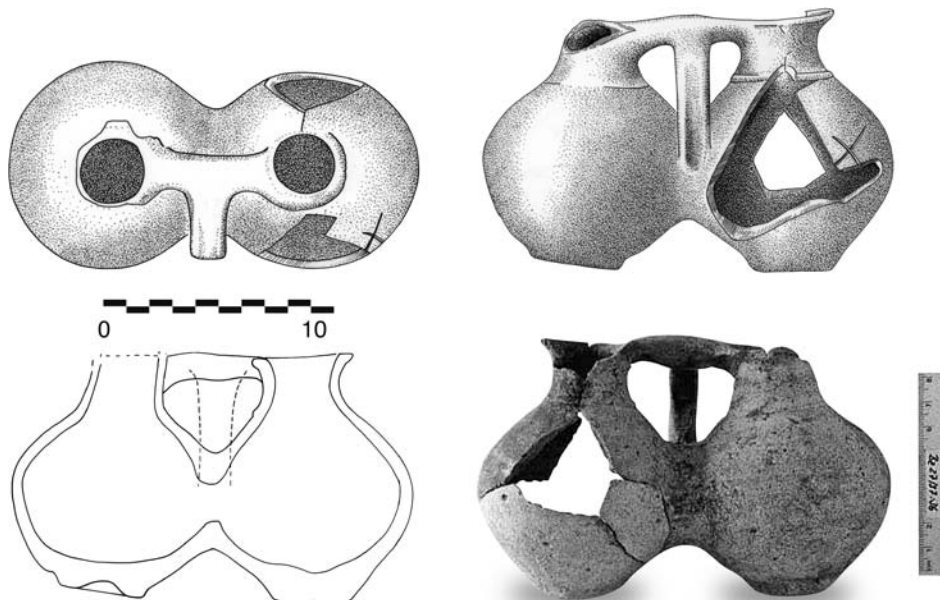

Bz 27/37:36

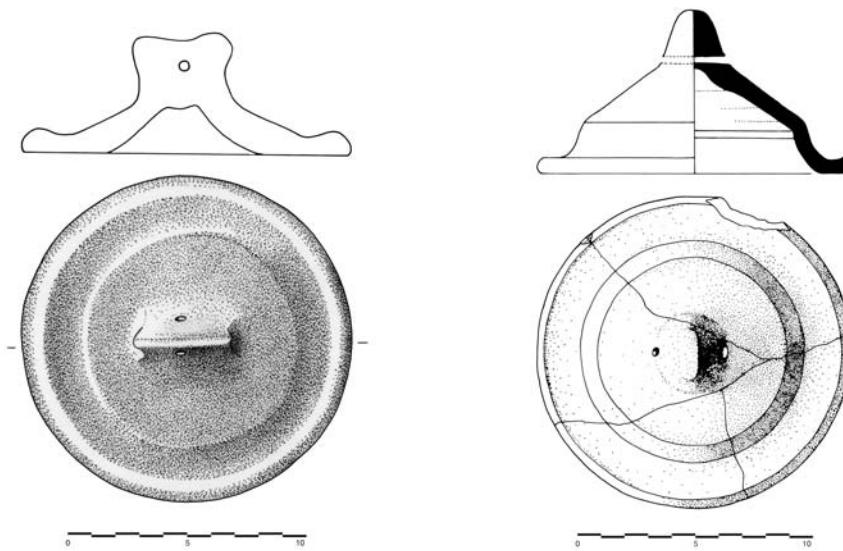

Bz 30/40:19



Bz 33/43:3

Plate 18 Lids and exceptional small jars.

اللوحة ١٨ الأغطية والجرار الاستثنائية.

Abstract

Several hundred pottery vessels of the Late Bronze Age have been excavated in the 'Weststadt' of Tall Bazi, a site in the Tishreen dam region of North Syria. The 'Weststadt' is a single period suburban extension of the settlement. Since it was violently destroyed, most of the pottery was found in primary context in the houses and was part of the inventory in use at the moment of the settlement's abandonment.

After a short description of the site and the architecture of the 'Weststadt', the typical pottery

assemblage in a typical house will be discussed and the 22 main ceramic types will be described. Thereafter the functions of the vessels will be investigated through the analysis of form, contents, and context incorporating the relevant textual evidence. This will be supplemented by a study of the manufacturing techniques of the local and imported pottery. Finally the preliminary dating of the pottery from the 'Weststadt' destruction level and the possible causes of this destruction will be examined.

ملخص

وصف الأنماط الفخارية الرئيسية الـ ٢٢. بعد ذلك سيجري التحقق من وظائف الأواني عن طريق تحليل الشكل والمحتويات والسياق الذي يتضمّن الدليل النصّي ذي الصلة. وسوف يستكمل هذا عن طريق دراسة تقنيات التصنيع للفخار المحلي والمستورد. في الختام سيجري تحريّ التاريخ الأولي للمنتجات الفخارية المكتشفة في سوية دمار "المدينة الغربية" بالإضافة إلى تحريّ الأسباب المحتملة لهذا الدمار.

كلمات البحث: العصر البرونزي الحديث، الفخار، سورية، التدبير المنزلي، التحليل الوظيفي، علم الآثار القياسي.

ملخص: تمّ الكشف عن عدّة مئات من الأواني الفخارية من عصر البرونز الحديث في المدينة الغربية في تل بزي، ويقع هذا التل في منطقة سدّ تشرين في شمال سورية. تمثّل "المدينة الغربية" توسّعاً مدينيّاً للمستوطنة يرجع إلى فترة زمنية واحدة. اكتشفت معظم المنتجات الفخارية ضمن سياقها الأثري الرئيسي في البيوت وذلك بسبب التدمير العنيف للمستوطنة، وكانت هذه المنتجات جزءاً من الموجودات لحظة هجر المستوطنة.

بعد وصف موجز للموقع ولعمارة "المدينة الغربية" ستتم مناقشة مجموعة المنتجات الفخارية النمطية الموجودة في منزل نموذجي وسيتم

Bibliography

- ARCHI, A.
1993 A Seal Impression from El-Qitar/Til-Abnu (Syria), *AnSt* 43, 203–206.
- ARNAUD, D.
1985–87 Recherches au pays d’Astata, *Emar VI/1*, 2, 3, 4.
- BACHELOT, L. – FALES, F. M. (eds.)
2005 Tell Shiukh Fawqani 1994–1998, *HANEM VI/1*.
- BEYER, D. (éd.)
1982 Meskéné – Emar. Dix ans de travaux 1972–1982.
- BEYER, D.
2001 Emar IV: Les sceaux, *Orbis Biblicus et Orientalis* 20.
- CULICAN, W. – MCCLELLAN, T. L.
1984 El-Qitar: First season of excavations, 1982–83, *Abr-Nahrain* 22, 29–63.
- CURVERS, H. H. – SCHWARTZ, G. M.
1997 Umm el-Marra, a Bronze Age Urban Center in the Jabbul Plain, Western Syria, *AJA* 101, 201–239.
- DORNEMANN, R. H.
1980 Tell Hadidi: an important center of the Mittanian period and earlier, in: J. Margueron (éd.), *Le Moyen Euphrate. Zone de contacts et d’échanges*, Actes du Colloque de Strasbourg, 10–12 mars, 1977, 217–234.
1981 The Late Bronze Age Pottery Tradition at Tell Hadidi, Syria, *BASOR* 241, 29–47.
- EINWAG, B.
2000 New Discoveries at Tall Bazi, Syria, in: P. Matthiae – A. Enea – L. Peyronel – F. Pinnock (eds.), *Proceedings of the First International Congress on the Archaeology of the Ancient Near East*, 397–410.
2007 Early Second Millennium Pottery of the Euphrates Region, in: P. Matthiae – F. Pinnock – L. Nigro – L. Peyronel (eds.), *From Relative Chronology to Absolute Chronology: The Second Millennium BC in Syria-Palestine*, Rome 2001, 195–208.
- EINWAG, B. – MCCLELLAN, T. – OTTO, A. – PORTER, A.
in prep. The Banat-Bazi Complex in the Third Millennium: Past Perspectives, Future Prospects.
- EINWAG, B. – OTTO, A.
1996 Tall Bazi – Vorbericht über die Untersuchungen 1994 und 1995, *DaM* 9, 15–45.
1999 Tall Bazi, in: G. del Olmo Lete – J.-L. Montero Fenollós (eds.), *Archaeology of the Upper Syrian Euphrates, The Tishreen Dam Area*, Proceedings of the International Symposium Held at Barcelona, January 28th–30th 1998, 179–191.
2001 Tall Bazi 1998 und 1999 – Die letzten Untersuchungen in der Weststadt, *DaM* 13, 65–88.
2006 Tall Bazi 2000 und 2001 – Die Untersuchungen auf der Zitadelle und in der Nordstadt, *DaM* 15, 105–130.
2012 Die Torlöwen an Tempel 1 von Tall Bazi und ihre Stellung in der Reihe steinerner Löwenorthostaten, in: H. Baker – K. Kaniuth – A. Otto (Hrsg.), *Stories of long ago. Festschrift für Michael D. Roaf*, *AOAT* 397, 91–115.
- FINKBEINER, U. – SAKAL, F.
2003 Emar 2002 – Bericht über die 5. Kampagne der syrisch-deutschen Ausgrabungen, *BaM* 34, 9–119.
- GATES, M.-H.
1988 Dialogues between ancient Near Eastern texts and the archaeological record: test cases from Bronze Age Syria, *BASOR* 270, 63–91.
- LONGACRE, W. A. (ed.)
1991 *Ceramic Ethnoarchaeology*.
- MALLOWAN, M.
1937 The excavations at Tall Chagar Bazar and an archaeological survey of the Habur region. Second campaign, 1936, *Iraq* 4, 91–154.
- MCCLELLAN, T. L.
1985 El Qitar: Second season of excavation, 1983–1984, *Abr-Nahrain* 23, 39–71.
1986 El Qitar: Third season of excavation, 1984–1985, *Abr-Nahrain* 24, 83–106.
1991 Banat, in: H. Weiss, *Archaeology in Syria*, *AJA* 95, 701–702.
1992 Twelfth Century BC Syria: Comments on H. Sader’s paper, in: W. A. Ward – M. S. Joukowsky (eds.), *The Crisis Years: The 12th Century B.C. from beyond the Danube to the Tigris*, 164–173.

- OTTO, A.
2001 Ein Wettergott auf dem Stier: Rekonstruktion eines spätbronzezeitlichen Kultgefäßes, *DaM* 13, 53–64.
2006a Alltag und Gesellschaft zur Spätbronzezeit: Eine Fallstudie aus Tall Bazi (Syrien), Subartu 19.
2006b Archaeological perspectives on the localization of Naram-Sin's Armanum, *JCS* 58, 1–43.
2008a Organization of Late Bronze Age Cities in the Upper Syrian Euphrates Valley, in: J. M. Córdoba – M. Molist – M. C. Pérez – I. Rubio – S. Martínez (eds.), *Proceedings of the Fifth International Congress on the Archaeology of the Ancient Near East, Madrid 2006*, 714–732.
2008b Ein echtes „Šekel von Kargamiš“ und die Einordnung einer nordsyrischen Siegelgruppe, in: D. Bonatz – R. M. Czichon – F. J. Kreppner (Hrsg.), *Fundstellen. Gesammelte Schriften ad honorem H. Kühne*, 82–89.
2012 Defining and Transgressing the Boundaries between Ritual Commensality and Daily Commensal Practices: the Case of Late Bronze Age Tall Bazi, in: S. Pollock (ed.), *Between Feasts and Daily Meals. Toward an Archaeology of Commensal Spaces, eTopoi Special Volume 2*, 179–195.
- OTTO, A. – EINWAG, B.
2007 Ein Tempel hoch über dem Euphrattal, *Antike Welt* 4/2007, 39–46.
- PFÄLZNER, P.
2001 Haus und Haushalt: Wohnformen des dritten Jahrtausends vor Christus in Nordmesopotamien, *DaF* 9.
- PORTER, A.
1995 The Third Millennium Settlement Complex at Tell Banat: Tell Kabir, *DaM* 8, 125–164.
2002 The Dynamics of Death. Ancestors, Pastoralism and the Origins of a Third Millennium City in Syria, *BASOR* 325, 1–36.
- PORTER, A. – MCCLELLAN, T. L.
1998 The Third Millennium Settlement Complex at Tell Banat: Results of the 1994 Excavations, *DaM* 10, 11–63.
- RICE, P. M.
1987 *Pottery Analysis – A Sourcebook*.
- SALLABERGER, W.
1996 Der babylonische Töpfer und seine Gefäße nach Urkunden altsumerischer bis altbabylonischer Zeit sowie lexikalischen und literarischen Zeugnissen, *MHE* III.
- SALLABERGER, W. – EINWAG, B. – OTTO, A.
2006 Schenkungen von Mittani-Königen an die Einwohner von Bašīru. Die zwei Urkunden aus Tall Bazi am Mittleren Euphrat, *ZA* 96, 69–104.
- SCHIFFER, M. B.
1972 Archaeological Context and Systemic Context, *American Antiquity* 37, 156–165.
- SCHWARTZ, G. M. – CURVERS, H. – DUNHAM, S. – STUART, B.
2003 A Third-Millennium B.C. Elite Tomb and Other New Evidence from Tell Umm el-Marra, Syria, *AJA* 107, 325–61.
- SKIBO, J. M.
1992 Pottery function: a use-alteration perspective, *Interdisciplinary contributions to archaeology*.
- SOLLEE, A.
2012 Zur Verteilung und Verbreitung der Lochbodengefäße im syro-mesopotamischen Kulturraum, in: H. Baker – K. Kaniuth – A. Otto (Hrsg.), *Stories of long ago. Festschrift für Michael D. Roaf*, *AOAT* 397, 625–647.
- WERNER, P.
2004 Tall Munbaqa - Ekalte III, *Die Glyptik*, *WVDOG* 108.
- ZARNKOW, M. – OTTO, A. – EINWAG, B.
2011 Interdisciplinary Investigations into the Brewing Technology of the Ancient Near East and the Potential of the Cold Mashing Process, in: W. Schiefenhövel and H. Mcbeth (eds.), *Liquid bread: beer and brewing in cross-cultural perspective*, 47–54.
- ZARNKOW, M. – SPIELEDER, E. – BACK, W. – SACHER, B. – OTTO, A. – EINWAG, B.
2006a Kaltmaischverfahren – eine mögliche Technologie im Alten Orient, *Die Brauwelt* 10, 272–275.
2006b Interdisziplinäre Untersuchungen zum altorientalischen Bierbrauen in der Siedlung von Tall Bazi/Nordsyrien vor rund 3200 Jahren, *Technikgeschichte* 73, 3–25.